

# 6-SLOT VXibus MAINFRAME USER MANUAL

## MODEL 1264C

PUBLICATION NO. 980827

### RACAL INSTRUMENTS

#### United States

(Corporate Headquarters and Service Center)  
4 Goodyear Street, Irvine, CA 92618  
Tel: (800) 722-2528, (949) 859-8999; Fax: (949) 859-7139

5730 Northwest Parkway Suite 700, San Antonio, TX 78249  
Tel: (210) 699-6799; Fax: (210) 699-8857

#### Europe

(European Headquarters and Service Center)  
18 Avenue Dutartre, 78150 LeChesnay, France  
Tel: +33 (0)1 39 23 22 22; Fax: +33 (0)1 39 23 22 25

29-31 Cobham Road, Wimborne, Dorset BH21 7PF, United Kingdom  
Tel: +44 (0) 1202 872800; Fax: +44 (0) 1202 870810

Via Milazzo 25, 20092 Cinisello B, Milan, Italy  
Tel: +39 (0)2 6123 901; Fax: +39 (0)2 6129 3606

Racal Instruments Group Limited, Technologie Park, D-51429 Bergisch Gladbach  
Tel: +49 2204 844205; Fax: +49 2204 844219

[info@racalinstruments.com](mailto:info@racalinstruments.com)  
[sales@racalinstruments.com](mailto:sales@racalinstruments.com)  
[helpdesk@racalinstruments.com](mailto:helpdesk@racalinstruments.com)  
<http://www.racalinstruments.com>  
[info@racalinstruments.de](mailto:info@racalinstruments.de)  
[www.racalinstruments.de](http://www.racalinstruments.de)



---

**PUBLICATION DATE: February 24, 2003**

Copyright 1998 by Racal Instruments, Inc. Printed in the United States of America. All rights reserved.  
This book or parts thereof may not be reproduced in any form without written permission of the publisher.

---

---

## THANK YOU FOR PURCHASING THIS RACAL INSTRUMENTS PRODUCT.

---

---

For this product, or any other Racal Instruments product that incorporates software drivers, you may access our web site to verify and/or download the latest driver versions. The web address for driver downloads is:

<http://www.racalstruments.com/downloads>

If you have any questions about software driver downloads or our privacy policy, please contact us at [info@racalstruments.com](mailto:info@racalstruments.com).

---

---

## WARRANTY STATEMENT

---

---

All Racal Instruments, Inc. products are designed and manufactured to exacting standards and in full conformance to Racal's ISO 9000\2000 procedures.

This warranty does not apply to defects resulting from any modification(s) of any product or part without Racal Instruments express written consent, or misuse of any product or part. The warranty also does not apply to fuses, software, non-rechargeable batteries, damage from battery leakage, or problems arising from normal wear, such as mechanical relay life, or failure to follow instructions.

This warranty is in lieu of all other warranties, expressed or implied, including any implied warranty of merchantability or fitness for a particular use. The remedies provided herein are buyer's sole and exclusive remedies.

For the specific terms of your standard warranty, or optional extended warranty or service agreement, contact your Racal customer service advisor. Please have the following information available to facilitate service.

1. Product serial number
2. Product model number
3. Your company and contact information

You may contact your customer service advisor by:

E-Mail:	<a href="mailto:Helpdesk@racalstruments.com">Helpdesk@racalstruments.com</a>	
Telephone:	+1 800 722 3262	(USA)
	+44(0) 8706 080134	(UK)
Fax:	+1 949 859 7309	(USA)
	+44(0) 1628 662017	(UK)

---

---

## RETURN of PRODUCT

---

---

Authorization is required from Racal Instruments before you send us your product for service or calibration. Call your nearest Racal Instruments support facility. A list is located on the last page of this manual. If you are unsure where to call, contact Racal Instruments, Inc. Customer Support Department in Irvine, California, USA at 1-800-722-3262 or 1-949-859-8999 or via fax at 1-949-859-7139. We can be reached at: [helpdesk@racalinstruments.com](mailto:helpdesk@racalinstruments.com).

---

---

## PROPRIETARY NOTICE

---

---

This document and the technical data herein disclosed, are proprietary to Racal Instruments, and shall not, without express written permission of Racal Instruments, be used, in whole or in part to solicit quotations from a competitive source or used for manufacture by anyone other than Racal Instruments. The information herein has been developed at private expense, and may only be used for operation and maintenance reference purposes or for purposes of engineering evaluation and incorporation into technical specifications and other documents which specify procurement of products from Racal Instruments.

---

---

## DISCLAIMER

---

---

Buyer acknowledges and agrees that it is responsible for the operation of the goods purchased and should ensure that they are used properly and in accordance with this handbook and any other instructions provided by Seller. Racal Instruments products are not specifically designed, manufactured or intended to be used as parts, assemblies or components in planning, construction, maintenance or operation of a nuclear facility, or in life support or safety critical applications in which the failure of the Racal Instruments product could create a situation where personal injury or death could occur. Should Buyer purchase Racal Instruments product for such unintended application, Buyer shall indemnify and hold Racal Instruments, its officers, employees, subsidiaries, affiliates and distributors harmless against all claims arising out of a claim for personal injury or death associated with such unintended use.

---

# FOR YOUR SAFETY

---

Before undertaking any troubleshooting, maintenance or exploratory procedure, read carefully the **WARNINGS** and **CAUTION** notices.



**CAUTION**  
RISK OF ELECTRICAL SHOCK  
DO NOT OPEN



This equipment contains voltage hazardous to human life and safety, and is capable of inflicting personal injury.



If this instrument is to be powered from the AC line (mains) through an autotransformer, ensure the common connector is connected to the neutral (earth pole) of the power supply.



Before operating the unit, ensure the conductor (green wire) is connected to the ground (earth) conductor of the power outlet. Do not use a two-conductor extension cord or a three-prong/two-prong adapter. This will defeat the protective feature of the third conductor in the power cord.



Maintenance and calibration procedures sometimes call for operation of the unit with power applied and protective covers removed. Read the procedures and heed warnings to avoid “live” circuit points.

Before operating this instrument:

1. Ensure the proper fuse is in place for the power source to operate.
2. Ensure all other devices connected to or in proximity to this instrument are properly grounded or connected to the protective third-wire earth ground.

If the instrument:

- fails to operate satisfactorily
- shows visible damage
- has been stored under unfavorable conditions
- has sustained stress

Do not operate until, performance is checked by qualified personnel.

# Racal Instruments

## EC Declaration of Conformity

We

Racal Instruments Inc.  
4 Goodyear Street  
Irvine, CA 92718

declare under sole responsibility that the

**1264C, 6-Slot 500W Mainframe, P/N 407647**  
**1264C-S-XXXX, 6-Slot Mainframe, P/N 407647-S-XXXX**

conforms to the following Product Specifications:

**Safety:** EN61010-1:1993+A2:1995

**EMC:** EN61326:1997+A1:1998, Class A

**Supplementary Information:**

The product herewith complies with the requirements of the Low Voltage Directive 73/23/EEC and the EMC Directive 89/336/EEC (modified by 93/68/EEC).

Irvine, CA, October 15, 2002

  
Engineering Director

This page was left intentionally blank.

---

## Table Of Contents

<b>Chapter 1</b> .....	1-1
<b>GETTING STARTED</b> .....	1-1
Product Description .....	1-1
Key Features .....	1-1
Portable Bench Top Mainframe .....	1-2
Rack Mount Configuration (5U Footprint) .....	1-3
Modular Mainframe Design .....	1-4
500 Watts Usable DC Power .....	1-5
Positive Pressure Cooling System .....	1-6
System Monitor .....	1-7
Rack Mount Options .....	1-8
Backplane .....	1-8
Items Shipped With The 1264C .....	1-9
Spares & Optional Equipment .....	1-9
<b>Chapter 2</b> .....	2-1
<b>CONFIGURING THE 1264C</b> .....	2-1
Using This Chapter .....	2-1
AC Mains Power .....	2-1
Site Considerations .....	2-1
Installing VXI Modules .....	2-2
Installation and Removal of Card Guide Covers .....	2-2
Installation of Rack Mount Options .....	2-3
Installing Blanking Panels .....	2-4
Connecting Chassis Ground .....	2-5
<b>Chapter 3</b> .....	3-1
<b>OPERATING THE 1264C</b> .....	3-1
Using This Chapter .....	3-1
1264C Front Panel .....	3-1
1264C Rear View .....	3-2
Power The Mainframe ON/OFF .....	3-2

---

Monitoring Basics.....	3-3
Backplane Connections.....	3-4
Basic Functional Check.....	3-7

## Chapter 4.....4-1

UNDERSTANDING THE 1264C.....	4-1
Overview.....	4-1
Power Supply.....	4-1
Power Supply Interconnections.....	4-1
Power Supply Protections.....	4-3
Backplane.....	4-3
AC Interface.....	4-4
Cooling System.....	4-4
(Freestanding Unit Description).....	4-4
Cooling The Power Supply.....	4-4
System Monitor.....	4-4
Voltage Monitor.....	4-6
Fan Monitor.....	4-6
Temperature Monitor.....	4-6
ACFAIL* and SYSRESET* Signals.....	4-6

## Chapter 5.....5-1

MAINTENANCE.....	5-1
What's In This Chapter.....	5-1
Calibration.....	5-1
Service Strategy.....	5-1
Service Interval.....	5-1
Preparation.....	5-1
Inspection and Cleaning.....	5-2
Interior Cleaning.....	5-2
Exterior Cleaning.....	5-2
Cleaning The Fan Filters.....	5-3
Modular Component Removal and Replacement.....	5-4
Tools Required.....	5-4
Removal and Replacement of The Fan Assembly.....	5-5
Removal and Replacement of The Power Supply Assembly.....	5-6
Removal and Replacement of The AC Mains Fuse.....	5-9
Removing and Replacing The Card Guides.....	5-11



---

Trouble-shooting The 1264C.....	5-12
Assembly Drawings.....	5-14
Parts List.....	5-44
<b>Chapter 6</b> .....	<b>6-1</b>
PRODUCT SUPPORT.....	6-1
Product Support.....	6-1
Warranty.....	6-1
Support Offices.....	6-2
Appendix A.....	A-1

---

## List Of Figures

Figure 1-1, 1264C Portable Mainframe In Bench Top Configuration.....	1-2
Figure 1-2, 1264C Rack Mount (5U Tall) Configuration .....	1-3
Figure 1-3, Modular Service Friendly Mainframe Design Features. ....	1-4
Figure 1-4, 1264C 500 Watt Modular Power Supply. ....	1-5
Figure 1-5, 1264C Positive Pressure Cooling System. ....	1-6
Figure 1-6, 1264C System Monitor .....	1-7
Figure 2-1, AirFlow Directors (Card Guide Covers).....	2-2
Figure 2-2, Blanking Panels.....	2-4
Figure 2-3, Connecting Safety Ground .....	2-5
Figure 3-1, 1264C Front View .....	3-1
Figure 3-2, 1264C Rear View .....	3-2
Figure 4-1, Functional Block Diagram For 1264C Mainframe .....	4-2
Figure 4-2, System Monitor Block Diagram.....	4-5
Figure 5-1, Cleaning The Fan Filter .....	5-3
Figure 5-2, Fan Assembly/Rear Panel Removal .....	5-5
Figure 5-3, Removing The Power Supply .....	5-6
Figure 5-4, Loosening The 14 Screws. ....	5-7
Figure 5-5 Removing and Replacing The AC Mains Fuse .....	5-9
Figure 5-6, Card Guide Removal and Replacement .....	5-11
Figure A-1 Mainframe Worst Case Slot Cooling Curve.....	A-3
Figure A-2 View of 1264C with Rack Mount Option .....	A-6

---

## List Of Tables

Table 1-1 1264C Available DC Current .....	1-5
Table 3-1 Monitoring Basics .....	3-3
Table 3-2 P1 Connector Pinouts .....	3-4
Table 3-3 P2 Connector Pinouts For All Non-Slot 0 Locations .....	3-5
Table 3-4 P2 Connector Pinouts for VXIbus Slot 0 .....	3-6
Table 3-5 Power Supply Voltages at the P1 and P2 Connectors.....	3-7
Table 5-1 Troubleshooting .....	5-13
Table A-1 AC Input Specifications.....	A-1
Table A-2 DC Output Power .....	A-2
Table A-3 Cooling .....	A-3
Table A-4 Safety .....	A-4
Table A-5 Environmental.....	A-4
Table A-6 Backplane.....	A-5
Table A-7 Mechanical .....	A-5
Table A-8 System Monitoring Specifications (Typical).....	A-6

---

This page was left intentionally blank.

# Chapter 1

## GETTING STARTED

---

### Product Description

The Model 1264C 6-Slot Mainframe is a 6-slotVXIbus Mainframe. The 1264C can accommodate 6 C-size VXI modules. The Model 1264C fully complies with the VXIbus Specification Revision 2.0 (and earlier) requirements and is VXIplug&play compatible.

### Key Features

Figures 1-1 through 1-6 and the descriptions below detail the key features of the 1264C.

#### Ease of Use

- **Light Weight Portable Mainframe.** The compact 1264C weighs only 27 pounds and is ideal for portable applications.
- **Fast Setup.** The 1264C backplane uses active-automatic VME interrupt acknowledge and bus grant daisy chaining. Manual configuration of backplane switch settings or jumpers has been eliminated.
- **Monitoring.** The 1264C standard monitoring gives you key system health status (Voltage, Fan, and Temperature) with front panel LED annunciators for each VXI voltage, the cooling fan, and temperature monitor.
- **Modular Power Supply, and Fan Assembly.** The 1264C modular system design results in a virtually wireless mainframe with low MTTR and high MTBF. See Figure 1-3.

## Portable Bench Top Mainframe

The 1264C is a portable high performance 6-slot VXI mainframe (21.31L x 8.71W x 16.75H inches).



Figure 1-1, 1264C Portable Mainframe In Bench Top Configuration.

## Rack Mount Configuration (5U Footprint)

The 1264C mainframe is designed for rack mounting in a 5U tall rack space.

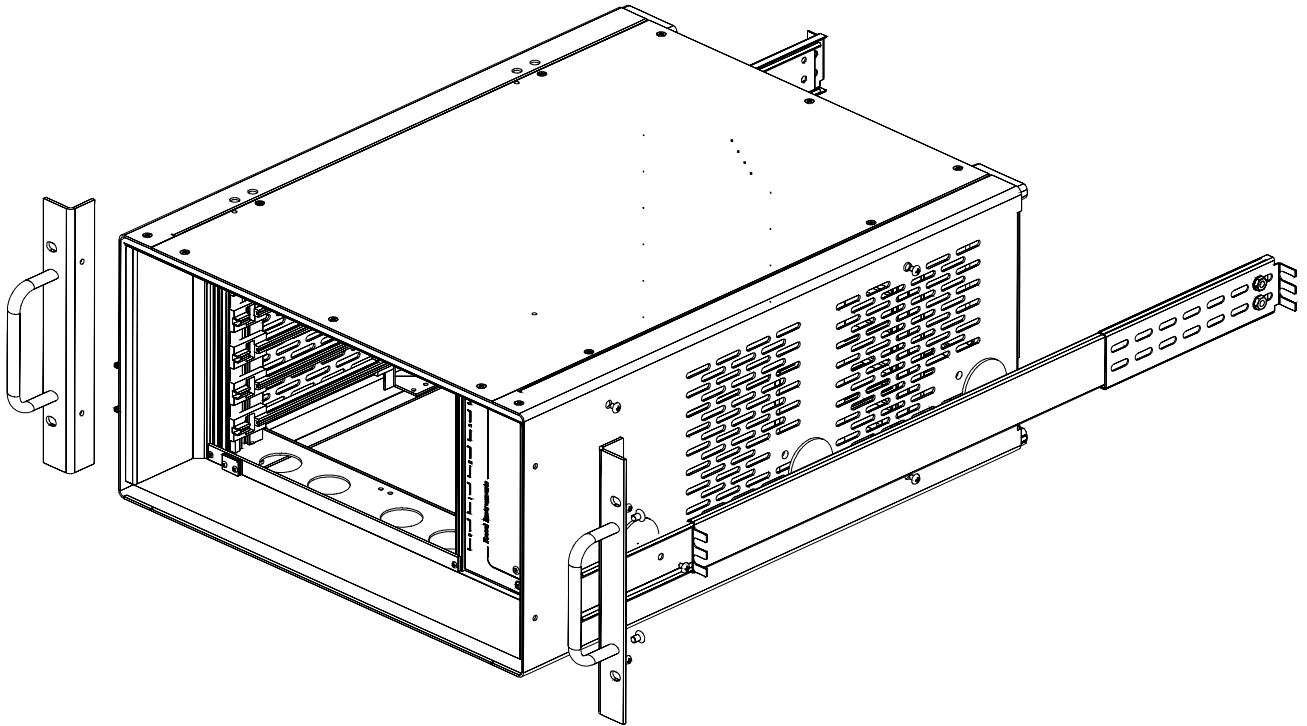

Figure 1-2, 1264C Rack Mount (5U Tall) Configuration

## Modular Mainframe Design

The 1264C highly modular design includes a wireless power interface between the power supply and the VXI backplane. The result is a low MTTR and high MTBF.

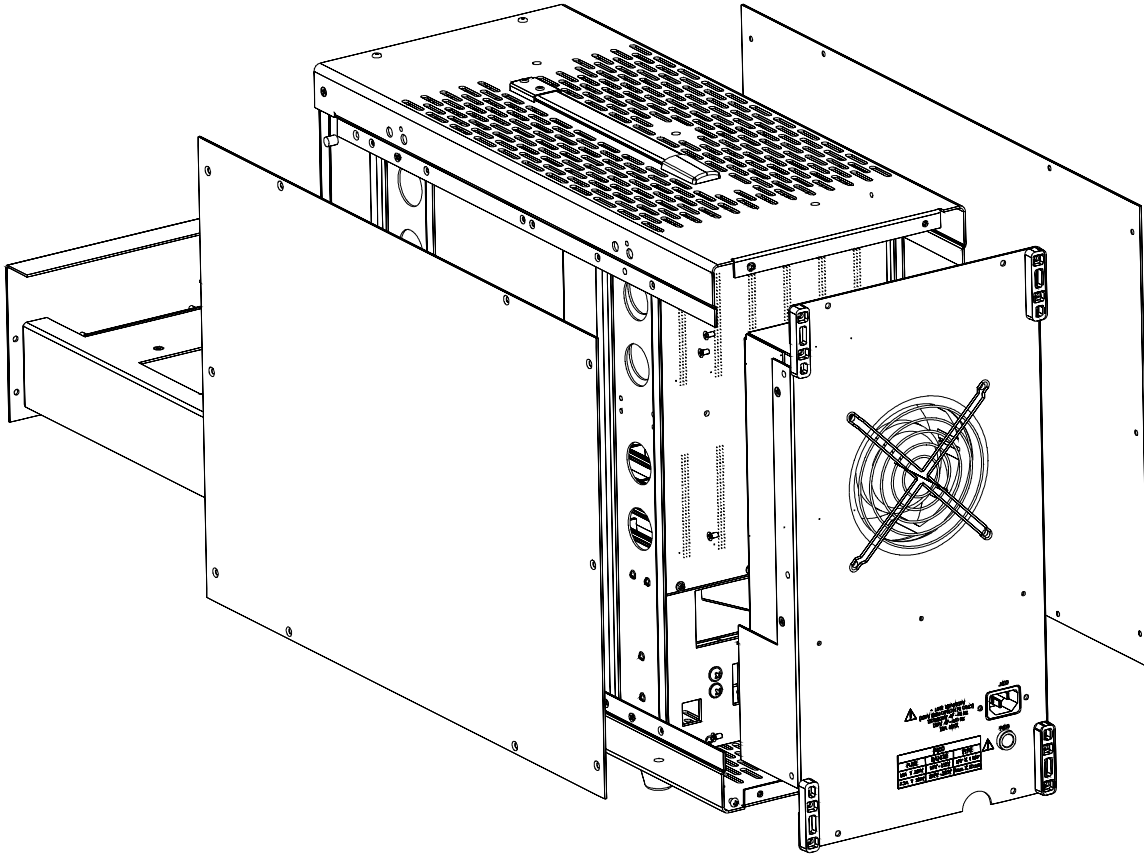

Figure 1-3, Modular Service Friendly Mainframe Design Features.



## 500 Watts Usable DC Power

Figure 1-4 depicts the 1264C mainframe's 500Watt modular power supply. Table 1-1 lists the available DC current for each VXI voltage.

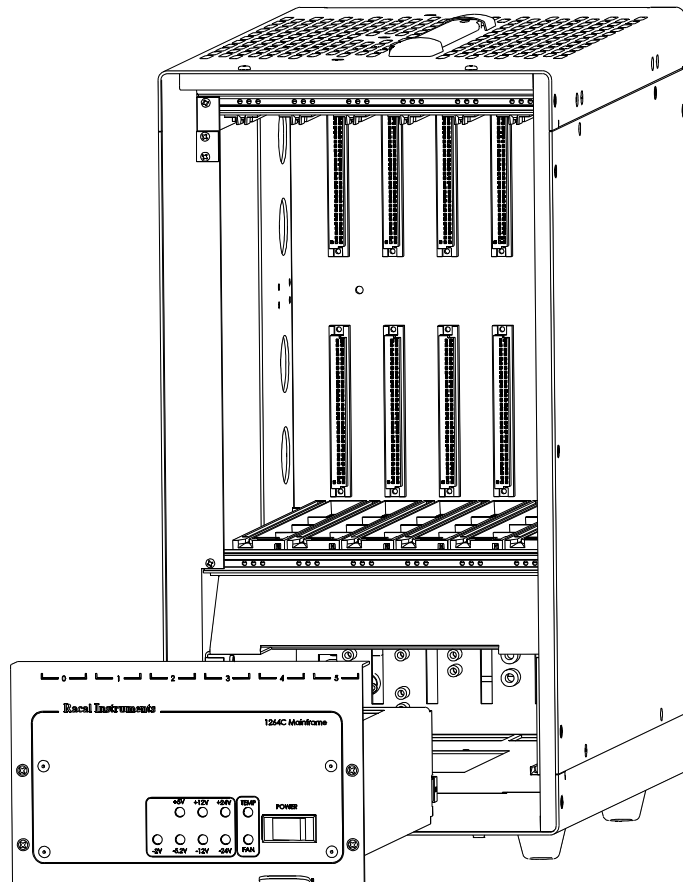

Figure 1-4, 1264C 500 Watt Modular Power Supply.

VXI Voltage	Available DC Current
+5V	45 Amps
-5.2V	30 Amps
-2V	15 Amps
+12V	8 Amps
-12V	8 Amps
+24V	4 Amps
-24V	4 Amps

Table 1-1 1264C Available DC Current

# Positive Pressure Cooling System

The 1264C uses forced air positive pressure cooling to direct air to the VXI modules.

Figure 1-5 details the cooling system.

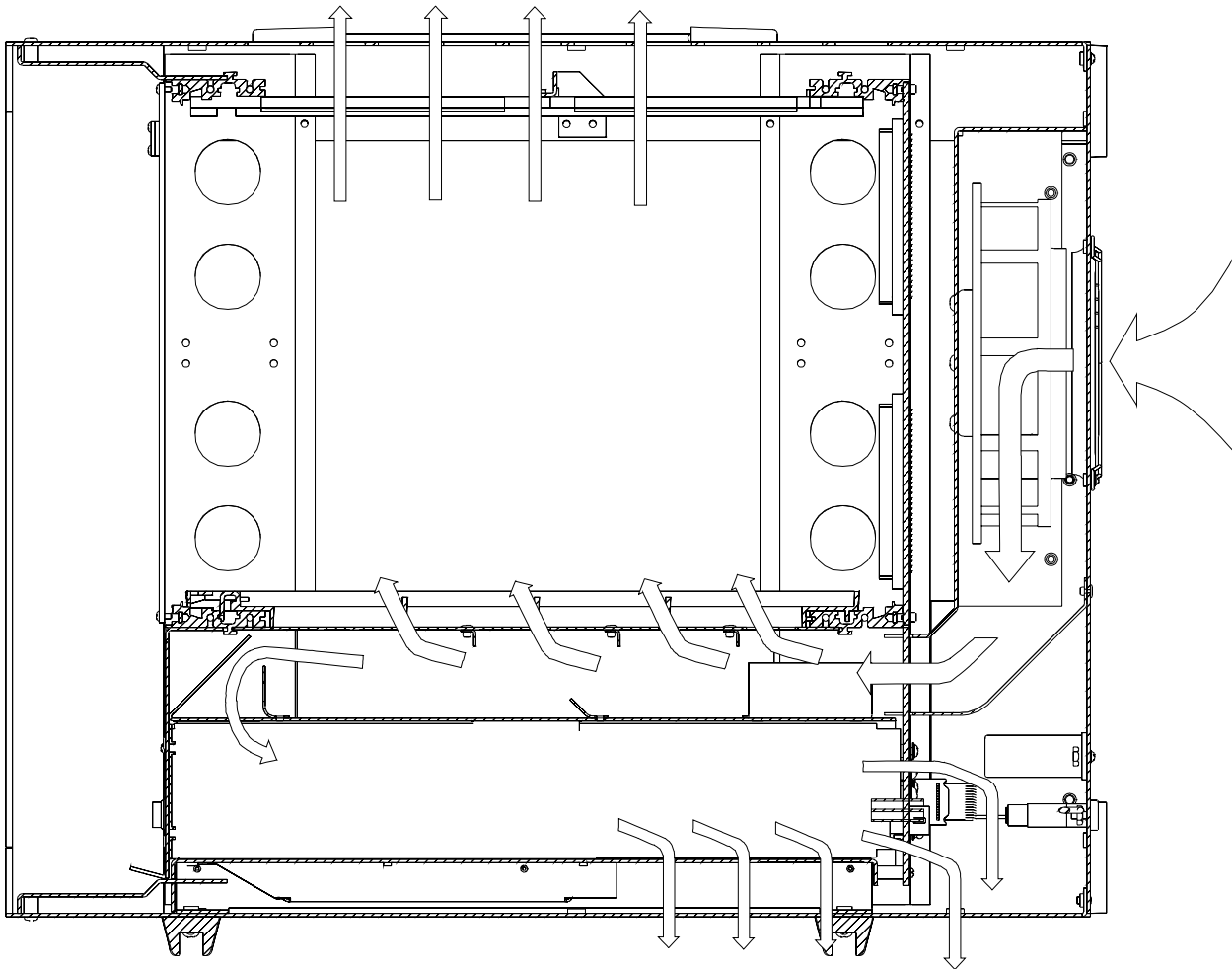

Figure 1-5, 1264C Positive Pressure Cooling System.

## System Monitor

The System Monitor features include a window comparator on each VXIbus voltage, fan failure indicator, and a power supply intake air temperature monitor. Each monitor includes a front panel LED annunciator.

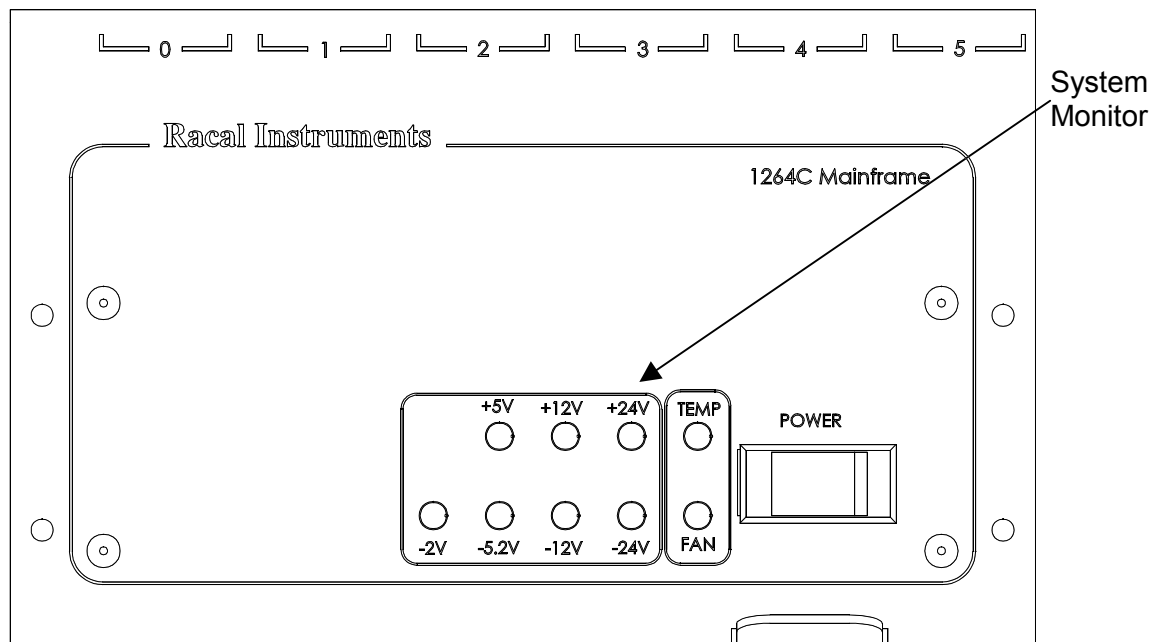

Figure 1-6, 1264C System Monitor

## Rack Mount Options

The 1264C is available with two rack mount options.

Option 01 includes rack mount ears, and slides.

Options 04 consist of rack mount ears only.

## Backplane

The 1264C backplane can accommodate up to six C-size VXI modules.

The 1264C has a jumperless auto-configurable backplane using active-automatic daisy chaining for the VME Interrupt acknowledge and bus grant daisy chain signal lines. This eliminates the need to manually configure the backplane.

Distribution of the CLK10 reference clock is full differential providing a low skew timing source.

Power is supplied to the backplane through a direct connection to the 1264C-power supply eliminating wiring and sub-backplane interconnects. The result is increased reliability and improved dynamic current performance.

## Items Shipped With The 1264C

Qty	Item	Part Number
1	Instruction Manual	980827
1	Power Cable	600620 Standard 600858 w/Option 71

## Spares & Optional Equipment

Spares Ordering Information		
Model	Description	Part Number
Card Guide Cover	Spare Card Guide Cover (block air through unused slots)	456271
Blanking Plate	Blanking Plates (to fill empty module slots)	404836
Option 01	Rack Ears and Slides	407670
Option 04	Rack Ears Only	407671
Option 15	Air Filter	407672
Option 23	Aluminum Front Door	407673
Option 51	Backplane w/Connector Shrouds Installed	407674
Option 52	Inter-Module Mainframe Shield Kit	407675
Option 71	230 Volt Fusing Option	407676

This page was left intentionally blank.

## CONFIGURING THE 1264C

---

### Using This Chapter

This section includes basic procedures to install and configure the 1264C mainframe. Use this chapter to:

- Review installation site considerations.
- Install VXI modules or optional card guide covers and blanking plates.
- Connect the chassis/safety ground.

**Installation and configuration information for optional equipment is provided with the option.**

### AC Mains Power

When the standard 1264C is shipped, it is configured for 120 VAC operation. Voltage selection switch S400 is set to the 115VAC position.

Should it be necessary to replace the AC mains fuse (F400), refer to Chapter 5: Removal and Replacement of the AC Mains Fuse.

---

**NOTE**

**Ordering Option 71 (P/N 407676) configures the 1264C for applications powered by 230 VAC power. The voltage selection switch S400 is set to the 230VAC position, a 6.3A Slo-Blow fuse is installed into F400, and an international power cord (P/N600858) replaces the domestic cord.**

---

### Site Considerations

The 1264C Mainframe is designed to be used freestanding (bench top) or in an instrument rack. Refer to Figure 1-5 for vent locations for the 1264C.

## Installing VXI Modules

Install C-size VXI modules directly into the C-size slots (6) of the mainframe by first placing the module's card edges into the front module guides (top then bottom). Slide the module to the rear of the mainframe until the module connectors mate solidly with the backplane connectors. Secure the module's front panel to the mainframe using the module's front panel mounting screws.

---

### CAUTION

**To avoid possible damages do NOT hot-plug install VXI modules (i.e., install with power on).**

---

## Installation and Removal of Card Guide Covers

In order to improve cooling of used slots in the VXI mainframe, a limited number of the optional card guide covers, P/N 456271, may be installed at empty C-size slot locations to redirect otherwise wasted airflow.

---

### CAUTION

**To maintain a balanced airflow throughout the system when using card guide covers, do not cover more than three empty slots at any time. If module density is low, space airflow covers evenly across the mainframe.**

---

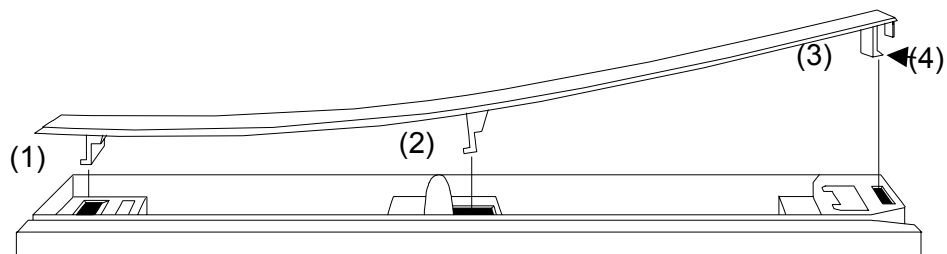

**Figure 2-1, AirFlow Directors (Card Guide Covers)**

1. Facing the front of the VXI mainframe, with one hand hold the cover by the front end where the "Racal" logo appears.
2. Select the slot to be covered by the cover. Insert the hook at the rear of the cover into the rectangular slot at the back of the cardguide (1). Apply a slight downward pressure on top of the cover (with the other hand) at the rear to engage the hook into the cardguide.



3. Slightly flex the cover upward at the front, maintaining pressure at the rear, and lower the center hook of the cover into the center rectangular slot in the cardguide (2).
4. Press down and back to allow both center and rear hook to engage fully into the cardguide.
5. Lower the front of the cover and allow the snap-in hook to rest on the cardguide (3).
6. With a slotted screwdriver or similar flat-bladed tool, depress the spring hook (4) at a slight downward angle, applying light pressure at the front end. This will cause the snap-hook to firmly seat the cover into place.
7. To remove the cover, depress the snap-in hook (4) from the front with a flat-bladed tool. This will unlatch the hook and allow removal from the cardguide at the front end.
8. Pull forward to release the fixed hooks at the center and rear.

## **Installation of Rack Mount Options**

Refer to page 5-41 for installation of Option 01, Rack Ears and Slides (P/N 407670).

Refer to page 5-42 for installation of Option 04, Rack Ears only (P/N 407671).

## Installing Blanking Panels

In order to optimize system performance, install optional blanking panels (P/N 404836) into unused or C-size empty slots. Secure with two captive mounting screws. Refer to Figure 2-3.

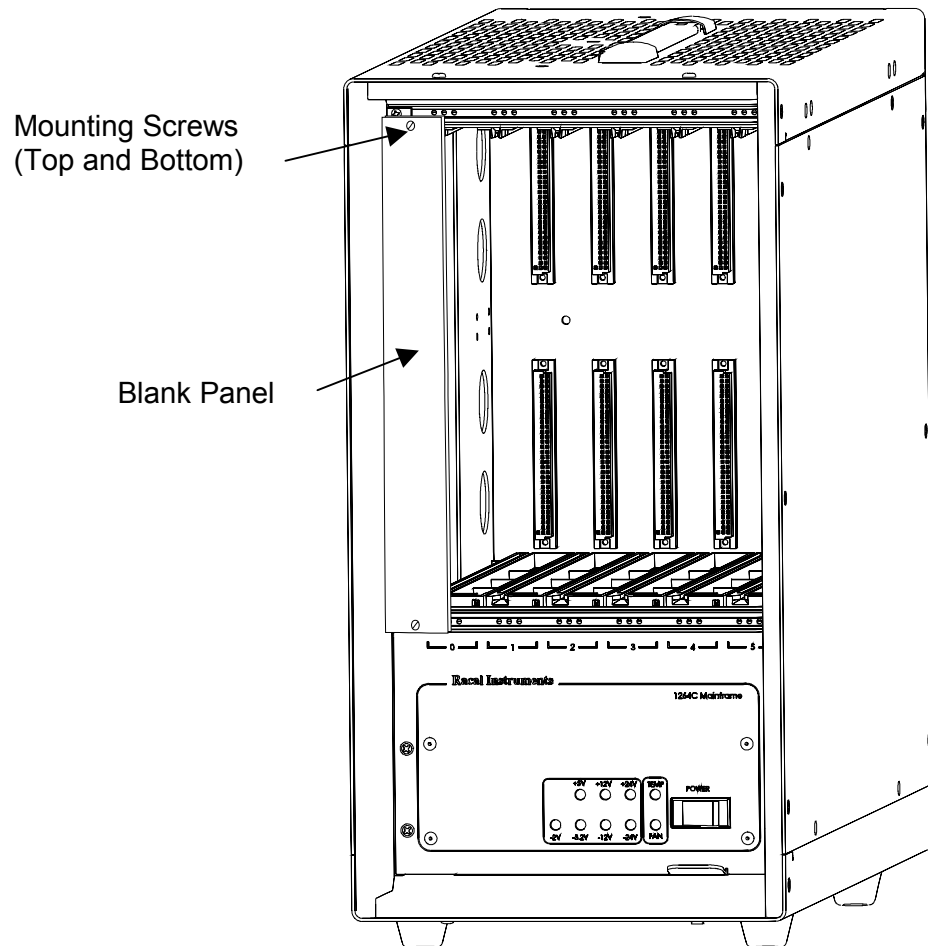

Figure 2-2, Blanking Panels

## Connecting Chassis Ground

Connect the Chassis (Safety) Ground to an earth or the ground of one or more instruments in the system. This ensures a common ground connection between instruments.

1. Connect a 16 AWG (1.3mm<sup>2</sup> or larger) wire to the 8-32 chassis (safety) grounding screw using a toothed grounding lug. The wire insulation must be green with a yellow stripe or non-insulated (bare wire).
2. Attach the opposite end of the wire to permanent earth ground earth (or to the ground of one or more instruments in the system) using toothed washers or a toothed lug.

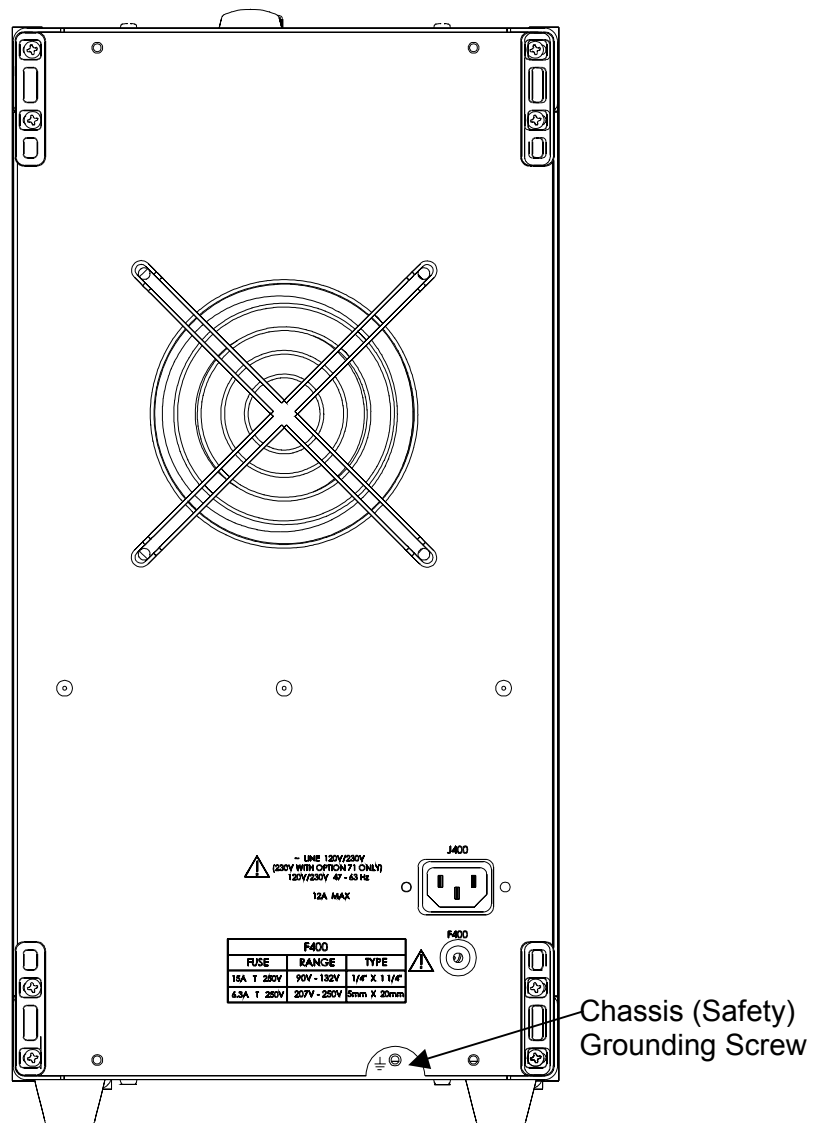

Figure 2-3, Connecting Safety Ground

This page was left intentionally blank.

# Chapter 3

## OPERATING THE 1264C

### Using This Chapter

Use this Chapter to:

- Review front and rear panel user interfaces.
- Power the mainframe on/off.
- Review Monitoring Basics guide to the front panel indicators.
- Perform basic functional check of the mainframe VXI voltages.
- Reference pin connections for VXI P1 and P2 Connectors.

### 1264C Front Panel

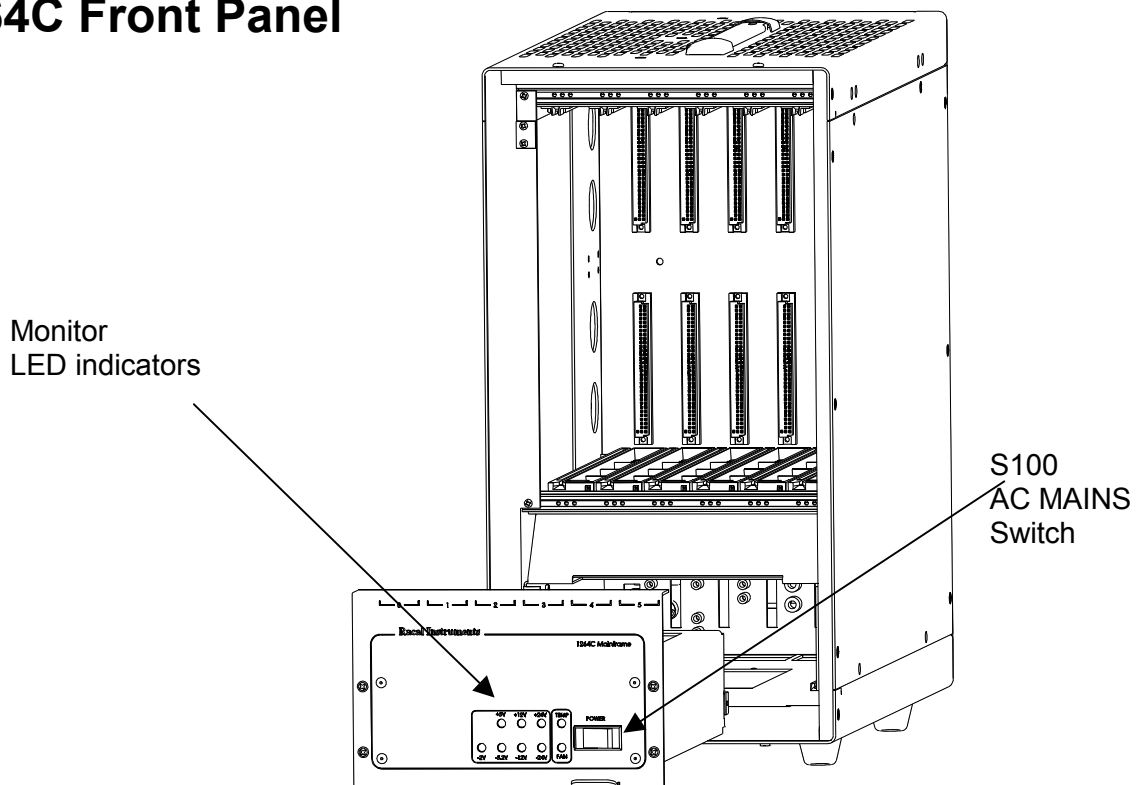
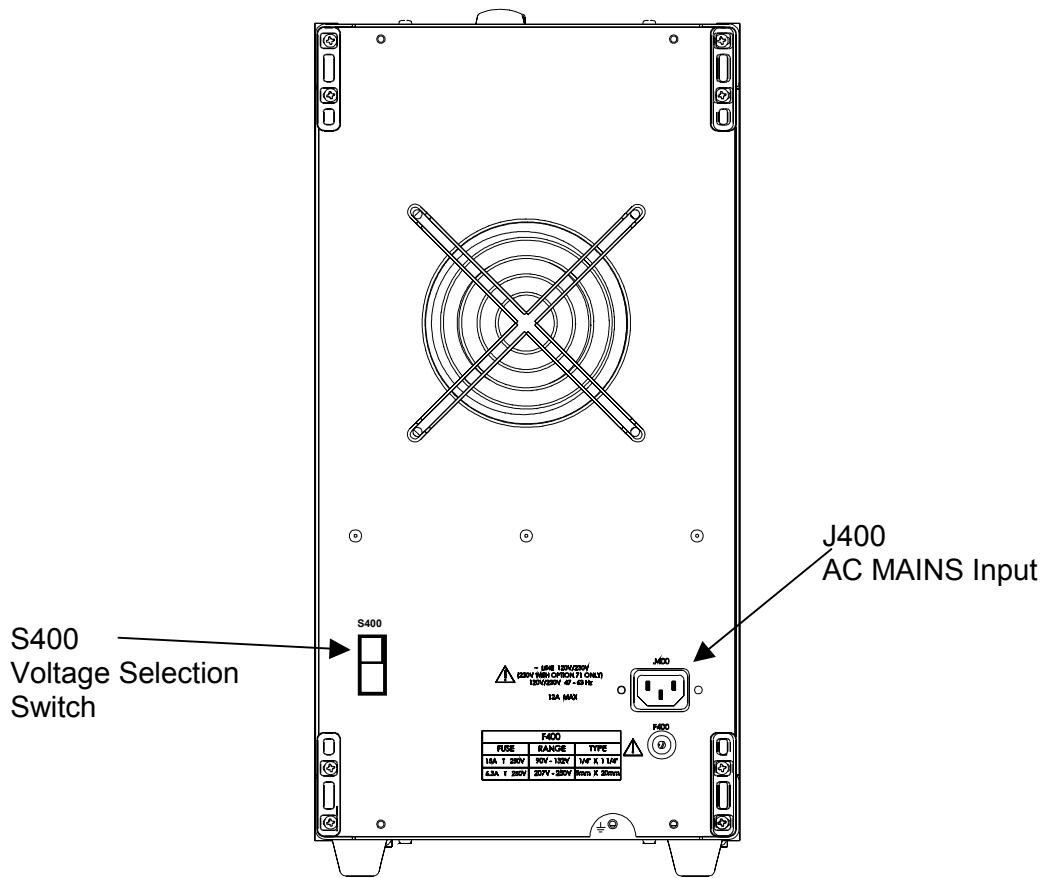

Figure 3-1, 1264C Front View

## 1264C Rear View



**Figure 3-2, 1264C Rear View**

Refer to Figures 3-1 and 3-2 and the description below.

## Power The Mainframe ON/OFF

1. Set front panel AC power switch S100 to the "O" or off position.
2. Connect the AC Power cord at J400 to the AC power source – 115 VAC (if S400 is set for 115VAC) for the standard 1264C, or 230 VAC (if S400 is set for 230VAC) if Option 71 is installed.
3. Turn the chassis on by setting the front panel switch S100 to the "I" or ON position.
4. Observe that the front panel LED indicators all turn Green. Note that the FAN LED indicator will illuminate RED while the fan ramps up to full speed. After approximately 20 seconds the FAN LED should turn Green.

**WARNING**

Option 71 (P/N 407676) is required for applications powered by 230 VAC power. The 1264C is configured for 230 VAC operation **ONLY** when Option 71 is ordered

## Monitoring Basics

Refer to Figures 3-1 and 3-2 while using Table 3-1 to interpret system monitor information. Refer to Section 7 Troubleshooting if a system fault is detected.

**Table 3-1 Monitoring Basics**

WHAT YOU SEE ON THE FRONT PANEL	WHAT IT MEANS
Green LED illuminated for:  <b>+5V</b> <b>+12V</b> <b>+24V</b> <b>-2V</b> <b>-5.2V</b> <b>-12V</b> <b>-24V</b>	VXI Voltages are within acceptable limits  $+4.56V \leq \text{+5V Rail} \leq +5.50V$ $+10.95V \leq \text{+12V Rail} \leq +13.20V$ $+21.90V \leq \text{+24V Rail} \leq +26.40V$ $-2.20V \leq \text{-2V Rail} \leq -1.83V$ $-5.72V \leq \text{-5.2V Rail} \leq -4.75V$ $-13.20V \leq \text{-12V Rail} \leq -10.95V$ $-26.40V \leq \text{-24V Rail} \leq -21.90V$
Green LED illuminated for :  <b>FAN</b>	Cooling fan is operating
Green LED illuminated for:  <b>TEMP</b>	Power supply intake air temperature $\leq 60^{\circ}\text{C}$

## Backplane Connections

Table 3-2 shows the P1 connector pinouts for all slots in the 1264C. Table 3-3 shows the P2 connector pinouts for all non-slot 0 slots. Table 3-4 shows the P2 connector pinouts for the VXIbus slot 0.

**Table 3-2 P1 Connector Pinouts**

Pin	Row A	Row B	Row C
1	D00	BBSY*	D08
2	D01	BCLR*	D09
3	D02	ACFAIL*	D10
4	D03	BG0IN*	D11
5	D04	BG0OUT*	D12
6	D05	BG1IN*	D13
7	D06	BG1OUT*	D14
8	D07	BG2IN*	D15
9	GND	BG2OUT*	GND
10	SYSCLK	BG3IN*	SYSFAIL*
11	GND	BG3OUT*	BERR*
12	DS1*	BR0*	SYSRESET*
13	DS0*	BR1*	LWORD*
14	WRITE*	BR2*	AM5
15	GND	BR3*	A23
16	DTACK*	AM0	A22
17	GND	AM1	A21
18	AS*	AM2	A20
19	GND	AM3	A19
20	IACK*	GND	A18
21	IACKIN*	SERCLK	A17
22	IACKOUT*	SERDAT*	A16
23	AM4	GND	A15
24	A07	IRQ7*	A14
25	A06	IRQ6*	A13
26	A05	IRQ5*	A12
27	A04	IRQ4*	A11
28	A03	IRQ3*	A10
29	A02	IRQ2*	A09
30	A01	IRQ1*	A08
31	-12V	+5V STDBY	+12V
32	+5V	+5V	+5V



Table 3-3 P2 Connector Pinouts For All Non-Slot 0 Locations

Pin	Row A	Row B	Row C
1	ECLTRG0	+5V	CLK10+
2	-2V	GND	CLK10-
3	ECLTRG1	RSV1	GND
4	GND	A24	-5.2V
5	LBUSA00	A25	LBUSC00
6	LBUSA01	A26	LBUSC01
7	-5.2V	A27	GND
8	LBUSA02	A28	LBUSC02
9	LBUSA03	A29	LBUSC03
10	GND	A30	GND
11	LBUSA04	A31	LBUSC04
12	LBUSA05	GND	LBUSC05
13	-5.2V	+5V	-2V
14	LBUSA06	D16	LBUSC06
15	LBUSA07	D17	LBUSC07
16	GND	D18	GND
17	LBUSA08	D19	LBUSC08
18	LBUSA09	D20	LBUSC09
19	-5.2V	D21	-5.2V
20	LBUSA10	D22	LBUSC10
21	LBUSA11	D23	LBUSC11
22	GND	GND	GND
23	TTLTRG0*	D24	TTLTRG1*
24	TTLTRG2*	D25	TTLTRG3*
25	+5V	D26	GND
26	TTLTRG4*	D27	TTLTRG5*
27	TTLTRG6*	D28	TTLTRG7*
28	GND	D29	GND
29	RSV2	D30	RSV3
30	MODID	D31	GND
31	GND	GND	+24V
32	SUMBUS	+5V	-24V

Table 3-4 P2 Connector Pinouts for VXibus Slot 0

Pin	Row A	Row B	Row C
1	ECLTRG0	+5V	CLK10+
2	-2V	GND	CLK10-
3	ECLTRG1	RSV1	GND
4	GND	A24	-5.2V
5	MODID12	A25	LBUSC00
6	MODID11	A26	LBUSC01
7	-5.2V	A27	GND
8	MODID10	A28	LBUSC02
9	MODID09	A29	LBUSC03
10	GND	A30	GND
11	MODID08	A31	LBUSC04
12	MODID07	GND	LBUSC05
13	-5.2V	+5V	-2V
14	MODID06	D16	LBUSC06
15	MODID05	D17	LBUSC07
16	GND	D18	GND
17	MODID04	D19	LBUSC08
18	MODID03	D20	LBUSC09
19	-5.2V	D21	-5.2V
20	MODID02	D22	LBUSC10
21	MODID01	D23	LBUSC11
22	GND	GND	GND
23	TTLTRG0*	D24	TTLTRG1*
24	TTLTRG2*	D25	TTLTRG3*
25	+5V	D26	GND
26	TTLTRG4*	D27	TTLTRG5*
27	TTLTRG6*	D28	TTLTRG7*
28	GND	D29	GND
29	RSV2	D30	RSV3
30	MODID00	D31	GND
31	GND	GND	+24V
32	SUMBUS	+5V	-24V

## Basic Functional Check

The functional check consists of checking the 1264C power supply voltages to the VXIbus limits at the P1 and P2 connectors using a digital voltmeter.

Referring to Tables 3-2 to 3-5 and Figure 3-1 connect one lead of the voltmeter to a supply pin. Connect the reference lead of the voltmeter to one of the ground pins. Compare each voltage reading to the values listed in Tables 3-5.

**Table 3-5 Power Supply Voltages at the P1 and P2 Connectors**

<b>P1/P2 Measurement Location (PIN)</b>	<b>Supply</b>	<b>VXI Acceptable Voltage Range</b>
P1-C32	+5V	4.875V to 5.25V
P1-A31	-12V	-12.6 to 11.64V
P2-C32	-24V	-25.2V to -23.28V
P2-C13	-2V	-2.1V to -1.9V
P1-C31	+12V	11.64V to 12.6V
P2-C31	+24V	23.28V to 25.2V
P2-C4	-5.2V	-5.46V to -5.044V
P1-C9, P2-C3	Logic Ground	

If the voltages are within the specified ranges, the mainframe complies with the VXI voltage limit specifications.

Note that the "Voltage Range" values in Table 3-5 are identical to the VXIbus Specification. The voltage range limits provided in Table 3-1 refer to the voltage monitor indicators on the 1264C front panel. The monitor will detect a voltage error when the limit is exceeded ( $V_{\text{nominal}} \pm 10\%$   $V_{\text{nominal}} \pm 4\%$  accuracy).

This page was left intentionally blank.

## UNDERSTANDING THE 1264C

---

### Overview

The 1264C Mainframe consists of the following major functional blocks.

- Power Supply
- Backplane
- Cooling System
- System Monitor

Figure 4-1 shows the functional block diagram of the 1264C Mainframe.

### Power Supply

The power supply accepts power from the AC mains and converts it to DC to power the following:

- VXI modules installed into the backplane
- Backplane terminations and daisy chaining logic
- System Monitor board

---

### Power Supply Interconnections

Power is supplied to the backplane through a board-to-board connection eliminating any wiring and sub-backplane interconnect boards. This design reduces the path impedance between the supply and the VXI modules receiving power, which results in improved dynamic current performance. See Appendix A for specifications.

Remote sense correction is provided for the +5V, -2V, and -5.2V VXI supplies. The remote sense signals are routed from PS1 through the monitor board (405141-J2) to the backplane via the 14-pin ribbon cable (405141-J1 to 405130-J50).

The Power Fail signal is routed from PS1 to the monitor board (405141-J2) and used to generate the VME signals ACFAIL\* and SYSRESET\*. These signals are then routed to the backplane through the 14-pin ribbon cable (405141-J1 to 405130-J50).

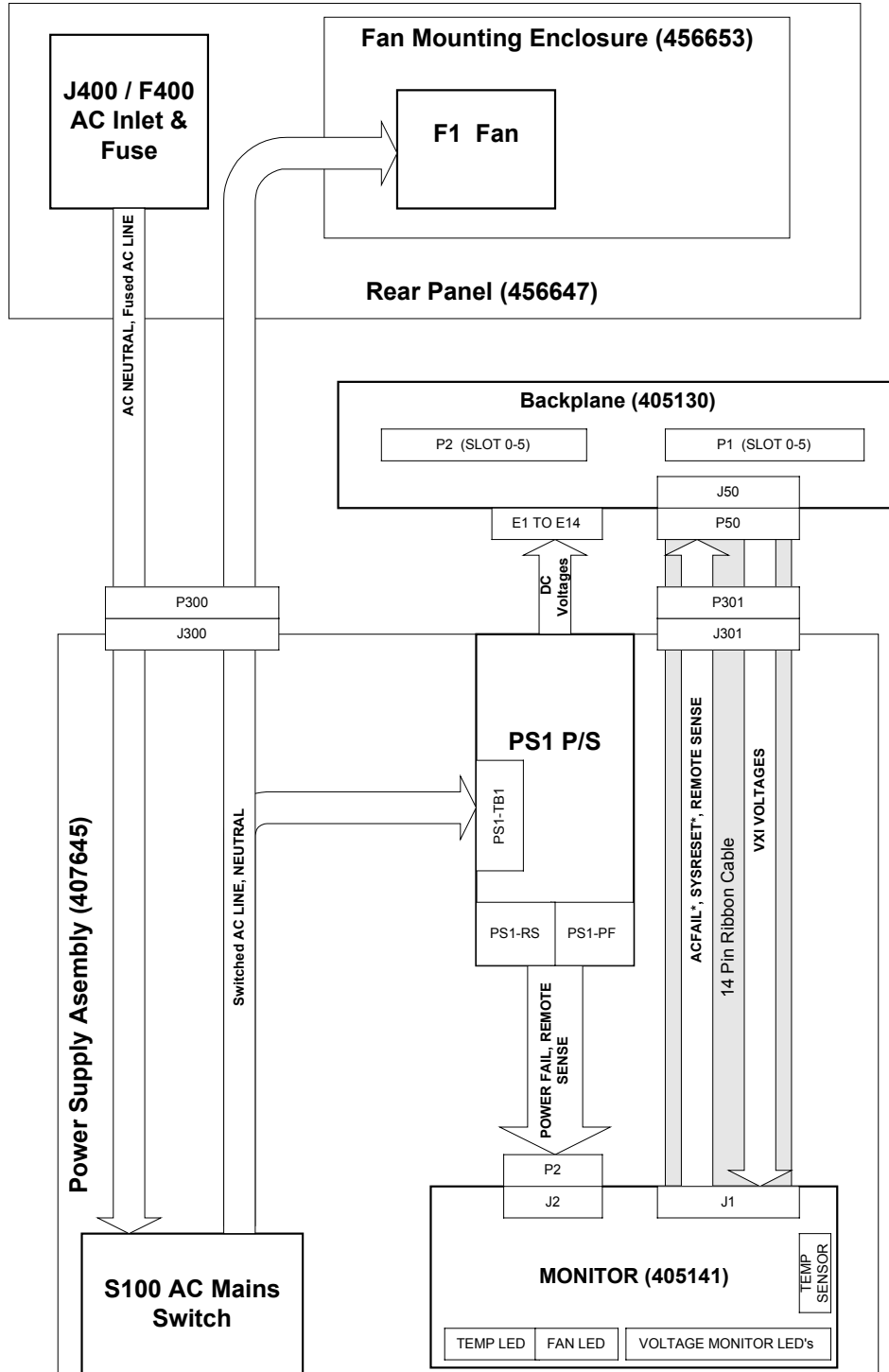

Figure 4-1, Functional Block Diagram For 1264C Mainframe

---

## Power Supply Protections

The seven VXIbus power supply outputs are protected for:

- Over-voltage
- Over-current and short circuit
- Over-temperature

The AC input of the power supply includes protections for:

- Input current fusing

See Appendix A for specification details pertaining to the above protections.

If any of the over-voltage or over-temperature protections are active, the power supplies will shutdown. This means the supply has turned itself off to protect the system. The AC Power switch S100 must be cycled to clear the shutdown condition. If the supply continues to shutdown then the external fault is still present.

If any of the over-current and short-circuit protections are active the power supply will go into current-limit and the voltage on the respective output may be reduced or at ground potential. These protections are self-correcting and the respective output will return to its nominal value when the fault is removed

## Backplane

The Backplane (405130) serves several functions

- Accommodates up to 6 C-size VXI.
- Rigid mechanical interface which accommodates a lifetime of insertions of VXI modules.
- Mechanically connects (at E1 to E14) to the power supply and distributes DC voltages and currents to VXI modules (through P1 and P2).
- Connects the VME communications interface across P1 and P2 to all slots.
- Connects the VXI extension signals across P2 rows A and C to all slots.
- Connects to the system monitor board through a 14-pin ribbon cable between J50 on the backplane and J301 on the power supply assembly (407645).

## AC Interface

AC Power supplied to the 1264C at J400 is fused at F400 and routed to switch S100 (main On/Off). The secondary side of S100 is routed to the power supply PS1 and to the cooling fan F1. The in-line connector interface J300/P300 provides the means of routing the AC power from the rear panel to the power supply assembly (including S100) and back to the cooling fan.

## Cooling System

The cooling fan F1 is located rear of the mainframe.

---

## (Freestanding Unit Description)

Module cooling air enters at the rear of a 1264C mainframe and is forced into a pressurized plenum below P2 the VXI modules. The high pressure in the plenum forces the air through a metered plate into the P2 connector side of the VXI modules. The air passing over components in the modules absorbs heat and exits at the P1 side of the modules.

---

## Cooling The Power Supply

Cooling air is forced into the power supply at the bottom front of the 1264C routed through the supply and exhausts at the bottom of the unit.

## System Monitor

The System Monitor features include a window comparator on each VXIbus voltage, fan failure indicator, and a power supply intake air temperature monitor. Each monitor includes a front panel LED.

Refer to Figure 4-2 System Monitor Block Diagram and the description below.



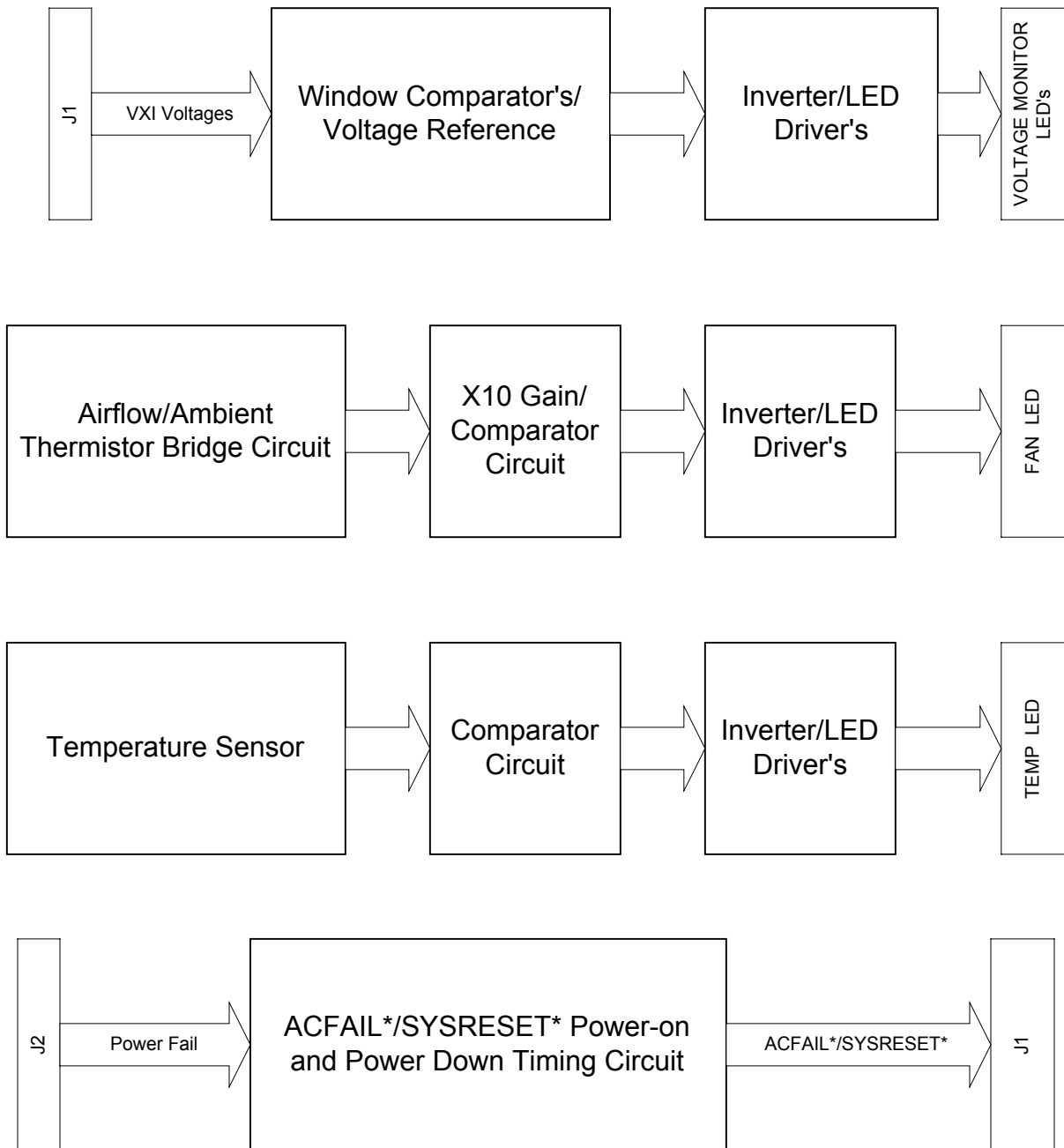

Figure 4-2, System Monitor Block Diagram

---

## Voltage Monitor

The VXI voltages are routed to the monitor board from the backplane through the 14-pin ribbon cable. The voltages are scaled and inverted (negative supplies only) and routed to the window comparators. The window comparator thresholds are set to detect that the supply is within  $\pm 10\%$  of nominal. A 2.5V reference is used to establish the window comparator thresholds. The reference can be adjusted via potentiometer R148 while measuring the voltage between J4-1 and J4-4 (GND). If the respective supply is within limits the front panel LED is Green. The LED will illuminate Red if the supply is out of limits.

---

## Fan Monitor

The fan monitor verifies that the fan is delivering cooling air by measuring the voltage difference between two self-heating thermistors. The ambient thermistor RT2 is isolated from the fan air stream. The air flow detecting thermistor RT1 is in the air stream. When the fan is operating properly the front panel LED is Green. The LED will illuminate Red if the fan is not operating.

---

## Temperature Monitor

The power supply intake air temperature is monitored by sensor U11. The sensor generates a voltage ( $500 \text{ mV} + 10 \text{ mV}/^\circ\text{C}$ ). The temperature monitor comparator is set to generate a fault (Red LED) at  $60^\circ\text{C}$  (or 1.10V).

---

## ACFAIL\* and SYSRESET\* Signals

The monitor board receives the Power Fail signal from the PS1 supply at J2-1. From this signal the VME signals ACFAIL\* and SYSRESET are generated with the appropriate timing relationship – see the VME specification revision C-1, or later. The signals are then routed to the backplane through the 14-pin ribbon cable between J1 (monitor) and J50 on the backplane.

## Chapter 5

# MAINTENANCE

---

### What's In This Chapter

This chapter provides information in regards to calibration and procedures for inspecting and cleaning the 1264C, removing and replacing mainframe components, and isolating problems to the module level. Refer to Chapter 4 Understanding The 1264C for theory of operation information.

### Calibration

The 1264C does not require calibration. To verify proper operation see the Basic Functional Check section in Chapter 3.

### Service Strategy

The service procedures in this manual provide removal and replacement procedures to repair the 1264C to the module level. Module level repairs are accomplished by exchanging faulty modules with known good modules or parts. No component-level repair is provided in this manual.

### Service Interval

Clean the fan filter (optional) at a maximum interval of six months. Depending upon the amount of usage and ambient dust levels in the operating environment, the filters may require more frequent cleaning.

Clean dust from the mainframe exterior (and interior) as needed, based on the operating environment. Periodic cleaning reduces instrument breakdown and increases reliability.

### Preparation

The information in this section is designed for use by qualified service personnel. Read the **For Your Safety** at the front of this manual and Service Strategy before attempting any procedures in this chapter. Refer to Chapter 3 Operating The 1264C for information on the location of controls, indicators, and connectors used with the mainframe.



---

**CAUTION**

Many components within the mainframe are susceptible to static discharge damage. Service the mainframe only in a static-free environment. Observe standard handling precautions for static-sensitive devices while servicing the mainframe. Always wear a grounded wrist strap, or equivalent, while servicing the mainframe.

---

## Inspection and Cleaning

The mainframe is inspected mechanically and electrically before shipment. It should be free of marks or scratches and should meet or exceed all electrical specifications. To confirm this, inspect the mainframe for physical damage incurred during transit. Retain the mainframe packaging if reshipment is necessary.

Cleaning procedures consist of exterior and interior cleaning of the mainframe and cleaning fan filters. Refer to your module user documentation for information on cleaning the individual VXIbus modules.

---

**CAUTION**

Always power off the mainframe and disconnect the power cord before cleaning or servicing the mainframe.

---

---

## Interior Cleaning

Use a dry, low-velocity stream of air to clean the interior of the mainframe. Use a soft-bristle brush for cleaning around components. If you must use a liquid for minor interior cleaning, use a 75% isopropyl alcohol solution and rinse with deionized water.

---

## Exterior Cleaning

Clean the exterior surfaces of the mainframe with a dry lint-free cloth or a soft-bristle brush. If any dirt remains, wipe with a cloth moistened in a mild soap solution. Remove any soap residue by wiping with a cloth moistened with clear water. Do not use abrasive compounds on any part of the mainframe.

---

**CAUTION**

Avoid getting moisture inside the mainframe during exterior cleaning - use just enough moisture to dampen the cloth.

---

Do not wash the front or rear panel connectors or switches. Cover these components while cleaning the mainframe.

---

Do not use chemical cleaning agents; they may damage the mainframe. Avoid chemicals that contain benzene, toluene, xylene, acetone, or similar solvents.

---

## Cleaning The Fan Filters

The fan filter (optional) is easily removed from the rear of the mainframe as shown in Figure 5-1.

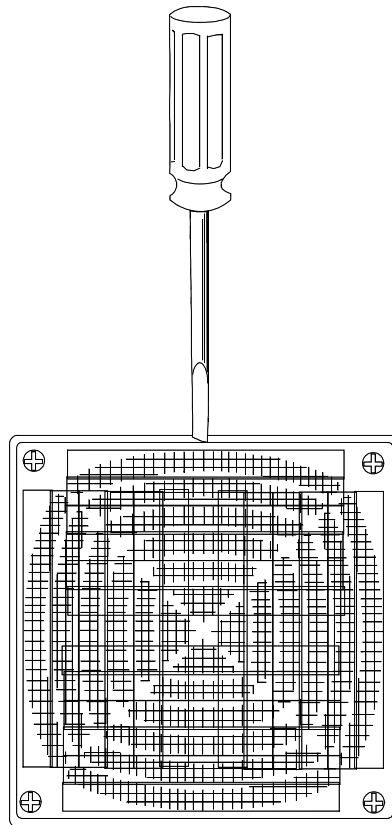

Figure 5-1, Cleaning The Fan Filter

1. Pry off the plastic grill retaining the supply fan filter. Use a flat blade screwdriver if necessary.
2. Remove the supply fan filter towards the rear.
3. Clean the supply fan filter by washing in mild soap solution, vacuuming or blowing air through the filter. Rinse the filter with water and dry before replacing it in the mainframe.

## **Modular Component Removal and Replacement**

The following procedures describe how to remove and replace module-level components of the 1264C Mainframe. Perform these procedures only as necessary as part of installation (e.g. fuse replacement), mainframe service, or repair. Refer to the Assembly Drawings in this chapter for an overview of the assembly and disassembly of the mainframe. See Troubleshooting for assistance in fault isolation.

---

### **CAUTION**

**Always power off the mainframe and disconnect the power cord before cleaning or servicing the mainframe.**

---

---

## **Tools Required**

The only tools required to disassemble the 1264C chassis to the module level are a medium flat blade and Phillips screwdriver.

## Removal and Replacement of The Fan Assembly

The fan assembly may be removed and replaced as described in the following steps. Refer to Figure 5-2.

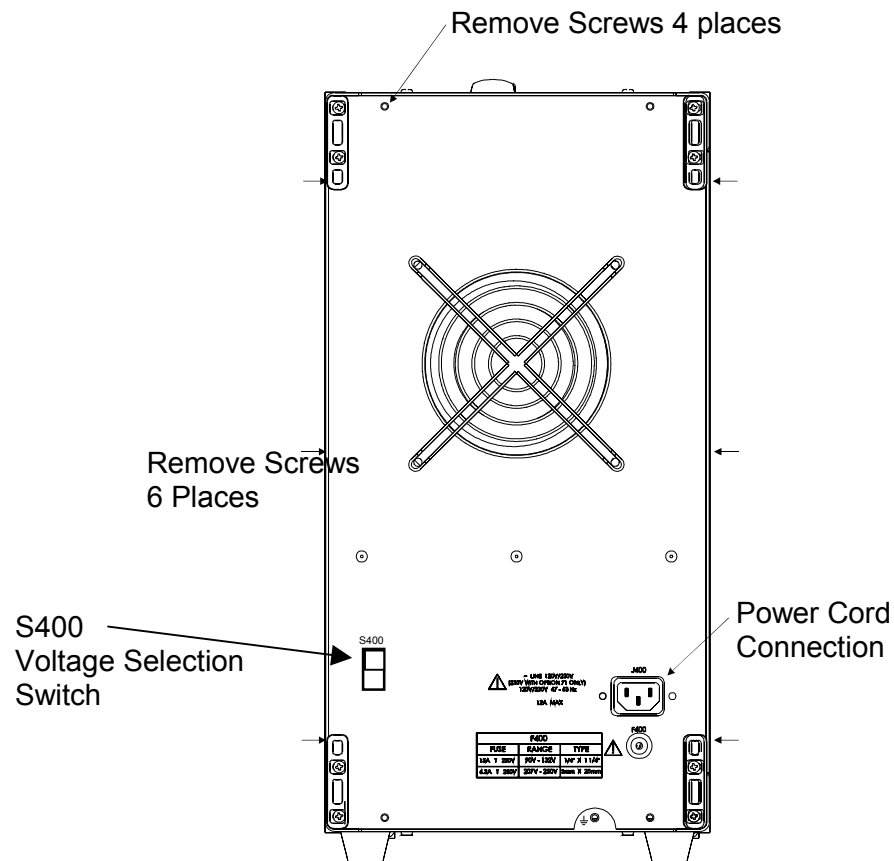

**Figure 5-2, Fan Assembly/Rear Panel Removal**

1. Remove the power cord. Loosen the retaining Phillips screws located on the rear and side panels of the mainframe. Remove the rear panel (with Fan) towards the rear being careful not to damage the fan wiring.
2. Disconnect the in-line connector (J300/P300) by grasping each mating half and gently pulling apart.
3. To reinstall the module fan assembly, reverse steps 1 and 2, above.

## Removal and Replacement of The Power Supply Assembly

To remove and install the power supply assembly from the mainframe. Refer to Figure 5-3 and perform the steps below.

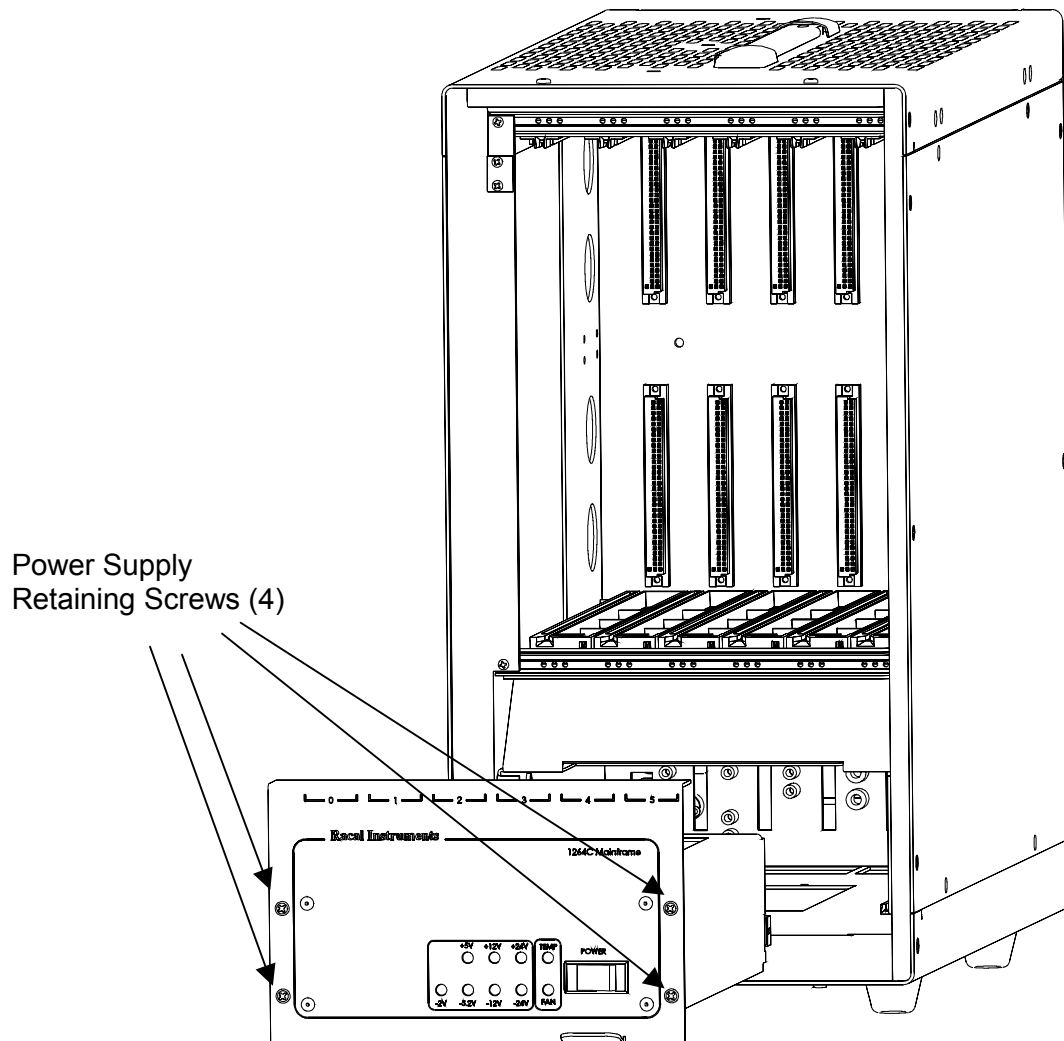

Figure 5-3, Removing The Power Supply



1. Unplug the AC power cord from the rear panel of the 1264C and remove the rear panel/fan assembly following the instructions from Removal and Replacement of The Fan Assembly, above
2. Disconnect the in-line connector (J301/P301) by grasping each mating half and gently pulling apart.
3. Disconnect (J300/P300)
4. Loosen the four screws which secure the power supply front panel to the mainframe. Loosen the fourteen screws at E1 to E14 which secure the power supply to the backplane (405130). See Figure 5-3 for locations retaining screws

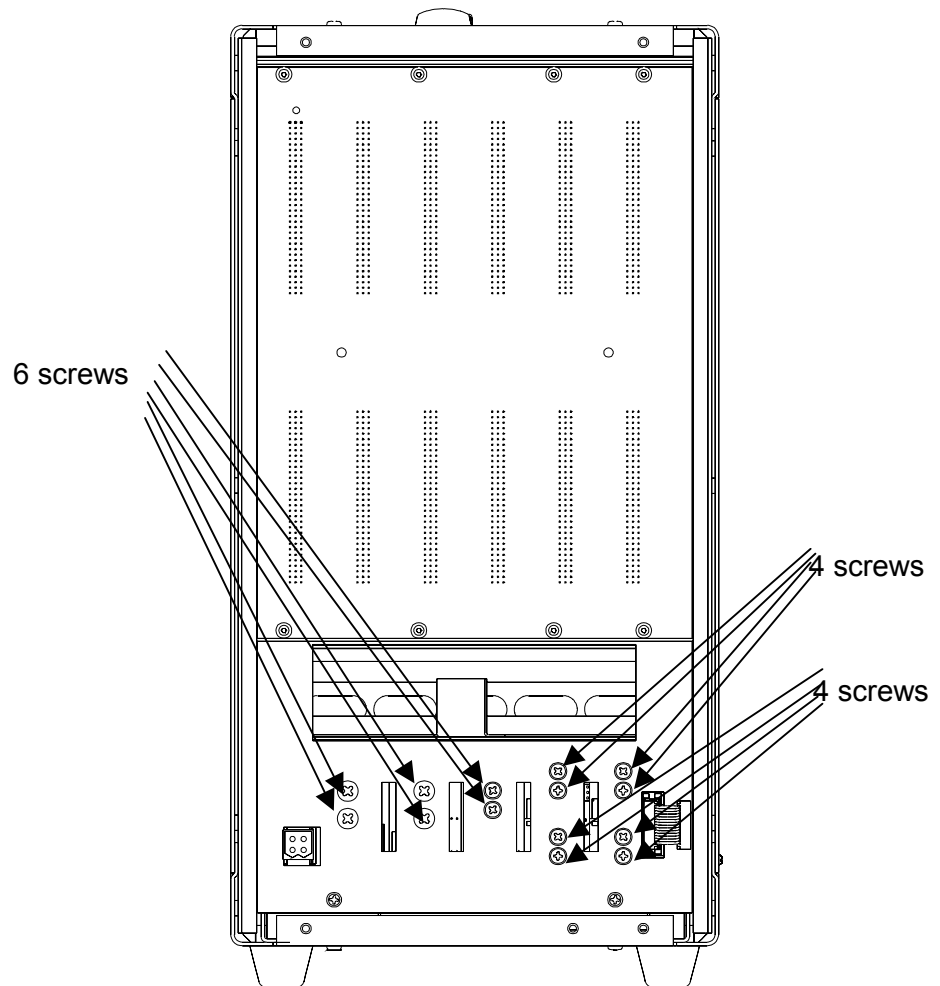

Figure 5-4, Loosening The 14 Screws.

5. Push at J300 on the rear of the supply assembly to slide the supply assembly towards the front of the mainframe.
6. Firmly grasp the tab (handle) at the bottom front of the power supply assembly and pull forward using a slight side to side rocking motion. If the power supply is difficult to remove, recheck to make sure all the retaining screws are disengaged.
7. To reinstall a power supply into the mainframe, first align the power supply with the cavity at the front of the mainframe. Note that the silkscreen on the supply rear panel will read correctly when the supply is in the proper orientation. Align the U-channel frame on guides.
8. Gently guide the power supply forward until engagement with the backplane is felt.
9. Tighten the four front panel screws and the fourteen backplane screws at E1 to E14.
10. Connect (J301/P301)
11. Connect ribbon cable connector (P300/J300)
12. Replace the rear panel/fan assembly..

## Removal and Replacement of The AC Mains Fuse

Complete the steps below while referring to Figure 5-5

---

### WARNING

To avoid electrical shock, the AC mains power input must be disconnected before replacement of the fuse.

---

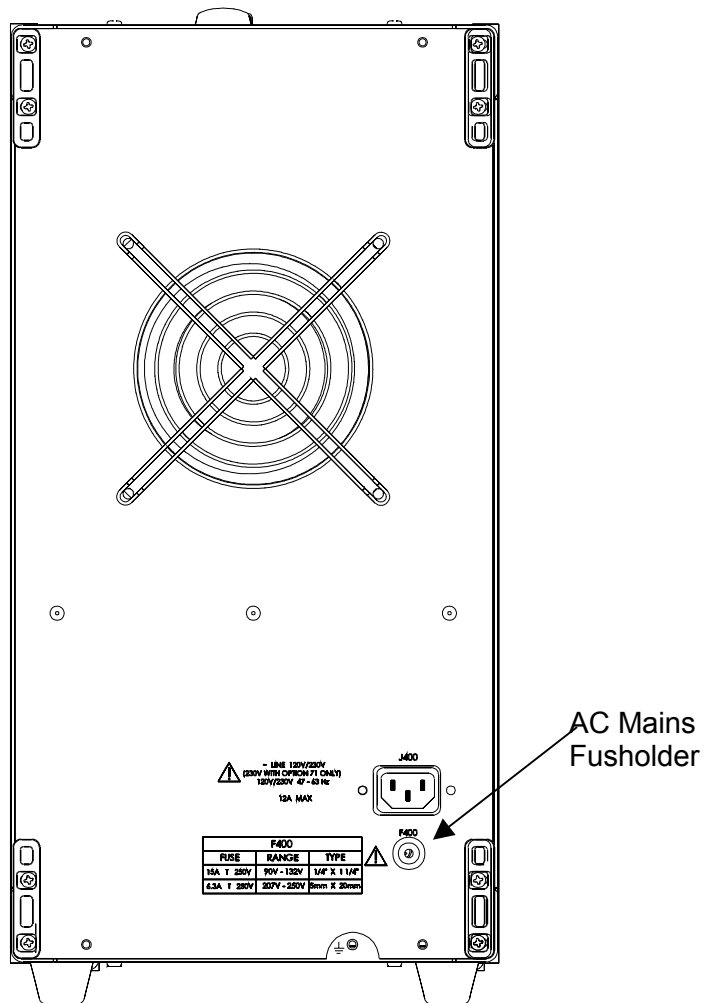
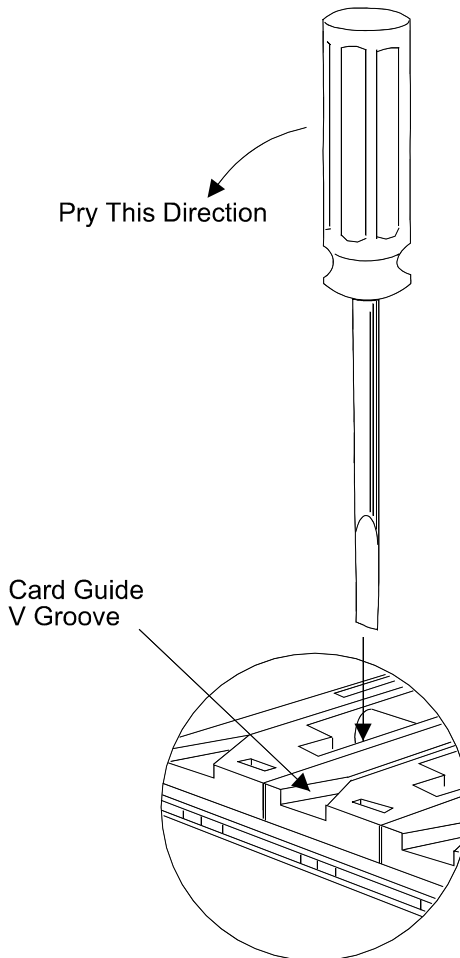

Figure 5-5 Removing and Replacing The AC Mains Fuse

1. Ensure AC mains input (J400) is disconnected.
2. Insert flat blade screwdriver into fuse carrier slot at F400 in power supply rear panel and rotate counter clockwise to remove.
3. To replace fuse, insert the fuse carrier and fuse assembly into the fuse housing opening for F400 on power supply.
4. Insert flat blade screwdriver into fuse carrier and rotate clockwise to lock fuse assembly in place.

## Removing and Replacing The Card Guides

Complete the steps below while referring to Figure 5-6 to remove and replace the card guides. The procedure applies to top and bottom card guides.



**Figure 5-6, Card Guide Removal and Replacement**

1. Insert a flat blade screwdriver into the slot in front of the retaining hook.
2. Gently pry the tab of the retaining hook to the rear, and lift the card guide, releasing it at the front.
3. Gently pull the card guide forward releasing it from the center and rear retaining hooks. Bowing the card guide is required to clear the front rail.
4. To replace, align the card guide with the mainframe front ensuring that the "V" groove is at the front.

5. Gently push down and to the rear to engage the hooks at the rear and middle of the card guide. Bowing the card guide is required to clear the front rail.
6. Allow the front retaining hook to rest on the front rail.
7. Insert a flat blade screwdriver into the slot in front of the retaining hook.
8. Gently pry the tab of the retaining hook to the rear, and press down the front of the card guide to snap into position.

## Trouble- shooting The 1264C

To troubleshoot the 1264C VXIbus mainframe to its component module level use Table 5-1 and Understanding the 1264C in Chapter 4.

“Fault condition” referenced in the PROBLEM column of Table 5-1 occurs when the monitored system status function (Voltage, Temperature, or Fan) is outside of its specified tolerance. For information on status indicators and tolerance limits refer to Specifications in Appendix A.

Table 5-1 Troubleshooting

PROBLEM	POSSIBLE CAUSES	WHAT TO DO
Unit does not Power On	<ul style="list-style-type: none"> <li>1264C mainframe not connected to power source.</li> </ul>	<ul style="list-style-type: none"> <li>Make sure that the 1264C is connected to a live electrical outlet and the AC power switch is on. Try operating another piece of equipment from this outlet.</li> </ul>
	<ul style="list-style-type: none"> <li>Blown AC Mains Fuse.</li> </ul>	<ul style="list-style-type: none"> <li>Unplug AC mains power and check the fuse. See "Removal and Replacement of the AC Mains Fuse" in Chapter 5.</li> </ul>
	<ul style="list-style-type: none"> <li>Power supply protections are active causing the supply to be "shutdown".</li> </ul>	<ul style="list-style-type: none"> <li>Refer to "Power Supply Protections" in Chapter 4.</li> <li>Cycle power to clear fault. If fault persists remove installed VXI modules (cycle power) until fault is cleared.</li> </ul>
	<ul style="list-style-type: none"> <li>Faulty AC wiring or bad front panel AC Power Switch</li> </ul>	<ul style="list-style-type: none"> <li>Verify integrity of AC wiring to AC Power switch and the switch itself. Contact customer service.</li> </ul>
Voltage alarm condition (RED LED illuminated).	<ul style="list-style-type: none"> <li>Faulty VXI module installed or voltage fault occurred</li> </ul>	<ul style="list-style-type: none"> <li>Cycle power.</li> <li>If fault persists remove installed VXI modules until fault indication is cleared.</li> </ul>
	<ul style="list-style-type: none"> <li>VXI supply is out of tolerance</li> </ul>	<ul style="list-style-type: none"> <li>Perform Basic Functional Check procedure from Chapter 3.</li> </ul>
Temperature alarm condition (RED LED illuminated).	<ul style="list-style-type: none"> <li>Supply intake temperature limit exceeded</li> </ul>	<ul style="list-style-type: none"> <li>Check for restrictions to airflow at mainframe intake and exhaust.</li> <li>Clean mainframe module cooling fan filter.</li> <li>Check ambient temperature.</li> </ul>
	<ul style="list-style-type: none"> <li>Insufficient module cooling air</li> </ul>	
Fan alarm condition	<ul style="list-style-type: none"> <li>Fan intake is blocked, or fan filter is clogged</li> </ul>	<ul style="list-style-type: none"> <li>Check for restrictions to airflow at mainframe intake and exhaust.</li> <li>Clean mainframe module cooling fan filter.</li> </ul>
	<ul style="list-style-type: none"> <li>S400 Voltage switch set to incorrect position</li> </ul>	<ul style="list-style-type: none"> <li>Set S400 to position that corresponds to the input power voltage.</li> </ul>

## Assembly Drawings

407647	1264C, Top Assembly.....	5-15
407646	1264C, Enclosure.....	5-17
407645	1264C, Power Supply.....	5-20
405130	PCB Assy, 6-Slot Backplane .....	5-21
435130	Schematics, 1264C 6-Slot Backplane .....	5-22
405141	PCB Assy, Monitor .....	5-36
435141	Schematics, 1264C Monitor .....	5-37
407670	Option 01, Rack Ears and Slide .....	5-41
407671	Option 04, Rack Ears Only.....	5-42
407672	Option 15, Air Filter .....	5-43





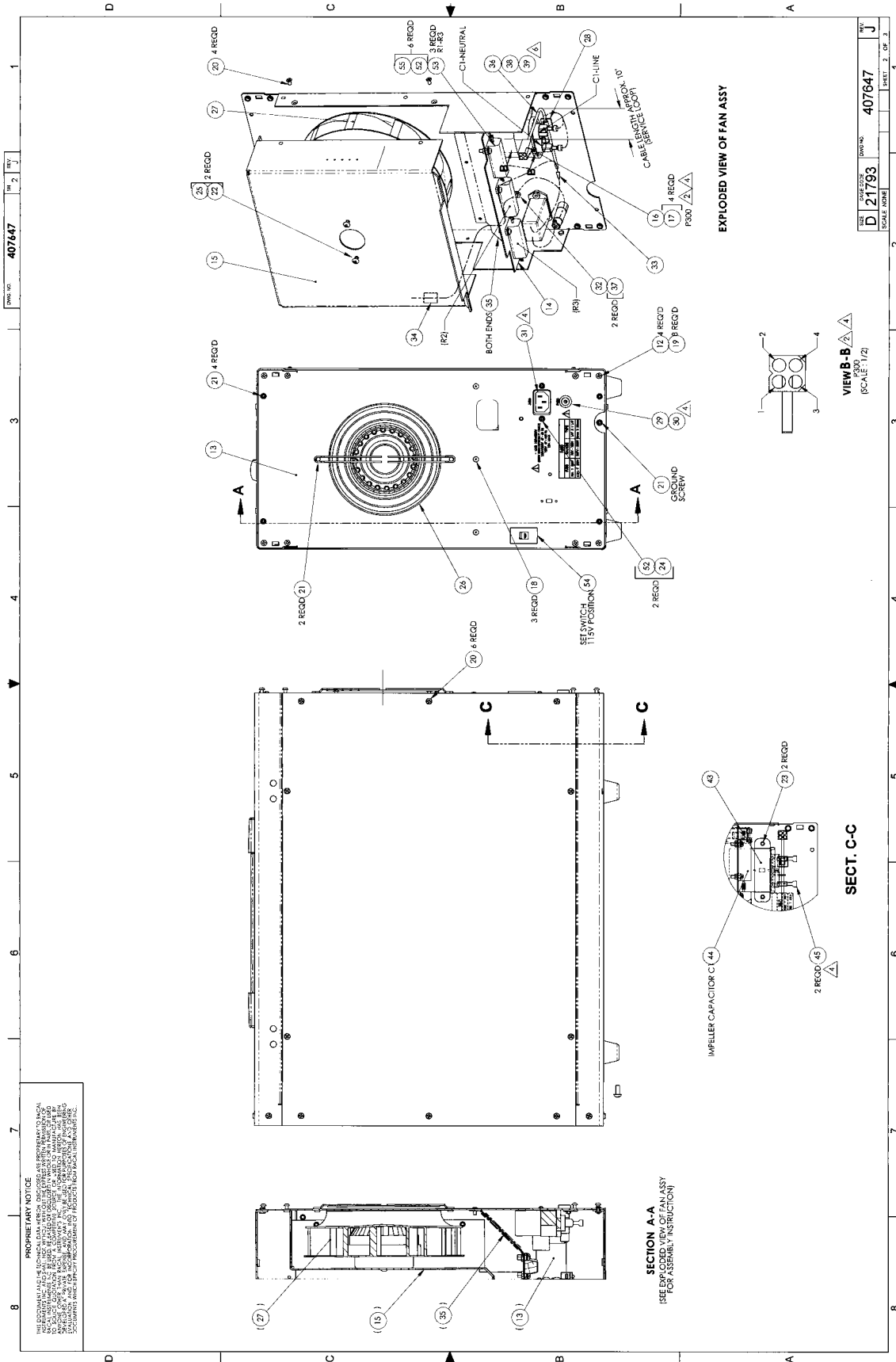

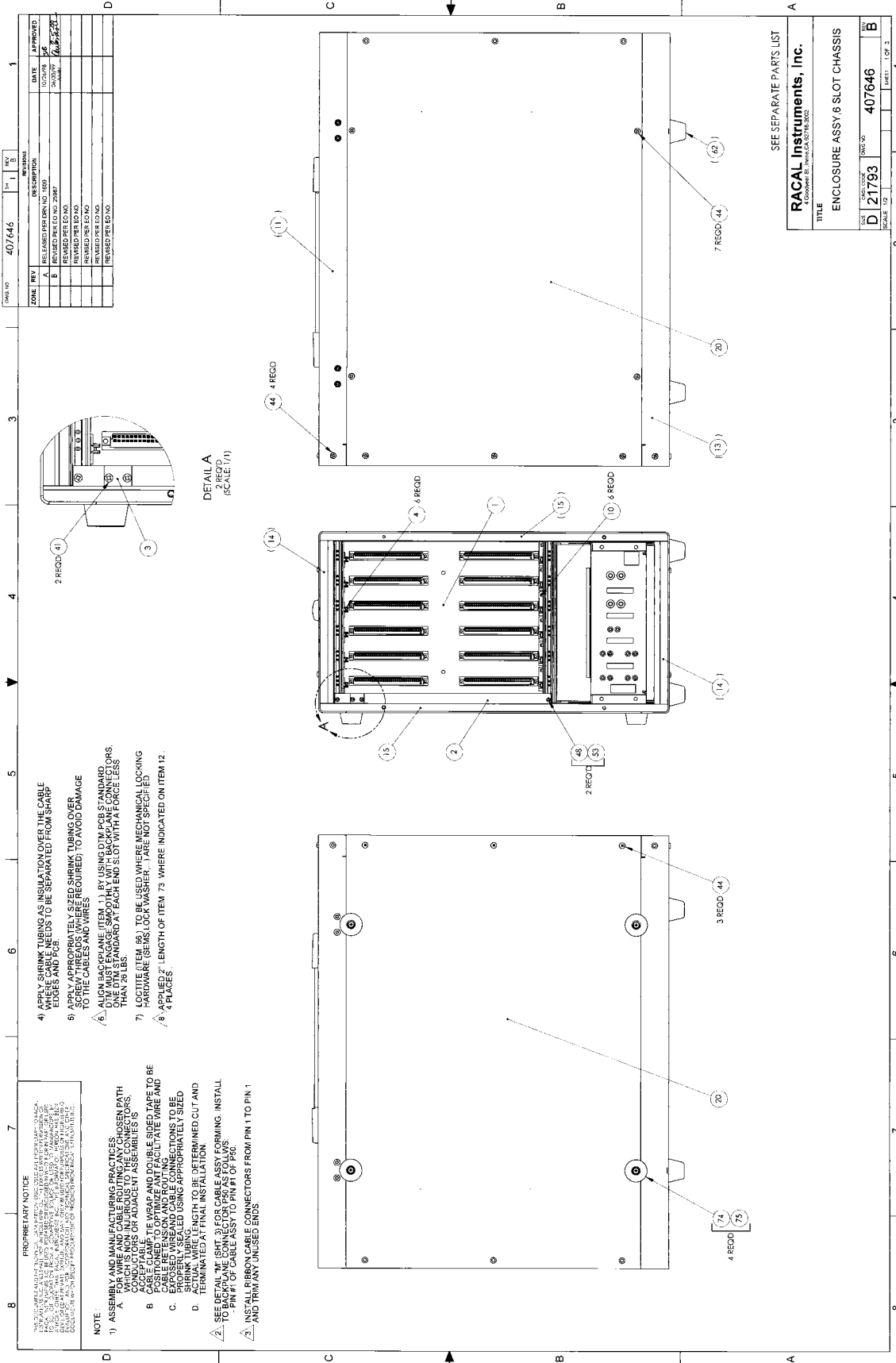

ZONE	REV	DESCRIPTION	DATE	APPROVED
A	1	RELEASED PER DRN NO. 1000	10/19/88	SK
B	1	REVISED PER DRN NO. 1007	11/07/88	SK
C	1	REVISED PER DRN NO. 1008	11/07/88	SK
D	1	REVISED PER DRN NO. 1009	11/07/88	SK

ZONE	REV	DESCRIPTION	DATE	APPROVED
A	1	RELEASED PER DRN NO. 1000	10/19/88	SK
B	1	REVISED PER DRN NO. 1007	11/07/88	SK
C	1	REVISED PER DRN NO. 1008	11/07/88	SK
D	1	REVISED PER DRN NO. 1009	11/07/88	SK

ZONE	REV	DESCRIPTION	DATE	APPROVED
A	1	RELEASED PER DRN NO. 1000	10/19/88	SK
B	1	REVISED PER DRN NO. 1007	11/07/88	SK
C	1	REVISED PER DRN NO. 1008	11/07/88	SK
D	1	REVISED PER DRN NO. 1009	11/07/88	SK

ZONE	REV	DESCRIPTION	DATE	APPROVED
A	1	RELEASED PER DRN NO. 1000	10/19/88	SK
B	1	REVISED PER DRN NO. 1007	11/07/88	SK
C	1	REVISED PER DRN NO. 1008	11/07/88	SK
D	1	REVISED PER DRN NO. 1009	11/07/88	SK

ZONE	REV	DESCRIPTION	DATE	APPROVED
A	1	RELEASED PER DRN NO. 1000	10/19/88	SK
B	1	REVISED PER DRN NO. 1007	11/07/88	SK
C	1	REVISED PER DRN NO. 1008	11/07/88	SK
D	1	REVISED PER DRN NO. 1009	11/07/88	SK

ZONE	REV	DESCRIPTION	DATE	APPROVED
A	1	RELEASED PER DRN NO. 1000	10/19/88	SK
B	1	REVISED PER DRN NO. 1007	11/07/88	SK
C	1	REVISED PER DRN NO. 1008	11/07/88	SK
D	1	REVISED PER DRN NO. 1009	11/07/88	SK

ZONE	REV	DESCRIPTION	DATE	APPROVED
A	1	RELEASED PER DRN NO. 1000	10/19/88	SK
B	1	REVISED PER DRN NO. 1007	11/07/88	SK
C	1	REVISED PER DRN NO. 1008	11/07/88	SK
D	1	REVISED PER DRN NO. 1009	11/07/88	SK

ZONE	REV	DESCRIPTION	DATE	APPROVED
A	1	RELEASED PER DRN NO. 1000	10/19/88	SK
B	1	REVISED PER DRN NO. 1007	11/07/88	SK
C	1	REVISED PER DRN NO. 1008	11/07/88	SK
D	1	REVISED PER DRN NO. 1009	11/07/88	SK

ZONE	REV	DESCRIPTION	DATE	APPROVED
A	1	RELEASED PER DRN NO. 1000	10/19/88	SK
B	1	REVISED PER DRN NO. 1007	11/07/88	SK
C	1	REVISED PER DRN NO. 1008	11/07/88	SK
D	1	REVISED PER DRN NO. 1009	11/07/88	SK

ZONE	REV	DESCRIPTION	DATE	APPROVED
A	1	RELEASED PER DRN NO. 1000	10/19/88	SK
B	1	REVISED PER DRN NO. 1007	11/07/88	SK
C	1	REVISED PER DRN NO. 1008	11/07/88	SK
D	1	REVISED PER DRN NO. 1009	11/07/88	SK

ZONE	REV	DESCRIPTION	DATE	APPROVED
A	1	RELEASED PER DRN NO. 1000	10/19/88	SK
B	1	REVISED PER DRN NO. 1007	11/07/88	SK
C	1	REVISED PER DRN NO. 1008	11/07/88	SK
D	1	REVISED PER DRN NO. 1009	11/07/88	SK

ZONE	REV	DESCRIPTION	DATE	APPROVED
A	1	RELEASED PER DRN NO. 1000	10/19/88	SK
B	1	REVISED PER DRN NO. 1007	11/07/88	SK
C	1	REVISED PER DRN NO. 1008	11/07/88	SK
D	1	REVISED PER DRN NO. 1009	11/07/88	SK

ZONE	REV	DESCRIPTION	DATE	APPROVED
A	1	RELEASED PER DRN NO. 1000	10/19/88	SK
B	1	REVISED PER DRN NO. 1007	11/07/88	SK
C	1	REVISED PER DRN NO. 1008	11/07/88	SK
D	1	REVISED PER DRN NO. 1009	11/07/88	SK

ZONE	REV	DESCRIPTION	DATE	APPROVED
A	1	RELEASED PER DRN NO. 1000	10/19/88	SK
B	1	REVISED PER DRN NO. 1007	11/07/88	SK
C	1	REVISED PER DRN NO. 1008	11/07/88	SK
D	1	REVISED PER DRN NO. 1009	11/07/88	SK

ZONE	REV	DESCRIPTION	DATE	APPROVED
A	1	RELEASED PER DRN NO. 1000	10/19/88	SK
B	1	REVISED PER DRN NO. 1007	11/07/88	SK
C	1	REVISED PER DRN NO. 1008	11/07/88	SK
D	1	REVISED PER DRN NO. 1009	11/07/88	SK

- NOTE:**
- 1) ASSEMBLY AND MANUFACTURING PRACTICES FOR WIRE AND CABLE ROUTING AND CHOSEN PATH SHALL BE IN ACCORDANCE WITH THE FOLLOWING: - CONDUITS OR ADJACENT ASSEMBLIES IS TO BE USED TO PROTECT WIRE FROM DAMAGE. - CABLES SHALL BE WRAP AND DOUBLE TAPE TO BE POSITIONED TO OPTIMIZE ANT FACILITATE WIRE AND EXPOSED WIRE AND CABLE CONNECTIONS TO BE SHOWN TO BE PROTECTED USING APPROPRIATELY SIZED SHRINK TUBING. - ACTUAL WIRE LENGTH TO BE DETERMINED CUT AND TERMINATED AT FINAL INSTALLATION.
  - 2) SEE BACKPLANE FOR CABLE ASSEMBLY FORMING. INSTALL TO EACH PLANE FOR CABLE ASSEMBLY FORMING. INSTALL - PIN #1 OF CABLE ASSY TO PIN #1 OF P40.
  - 3) INSTALL RIBBON CABLE CONNECTORS FROM PIN 1 TO PIN 1 AND TRIM ANY UNUSED ENDS.

- 4) APPLY SHRINK TUBING AS INSULATION OVER THE CABLE EDGES AND PCB.
- 5) APPLY APPROPRIATELY SIZED SHRINK TUBING OVER TO THE CABLE AND WIRES.
- 6) SLICEN BACKPLANE (ITEM 1) BY USING DTY FOR STANDARD. DTY MUST ENGAGE SMOOTHLY WITH BACKPLANE CONNECTORS. THIS MUST BE STANDARD AT EACH END SLOT WITH A FORCELESS.
- 7) LOCITE (ITEM 66) TO BE USED WHERE MECHANICAL LOCKING HARDWARE (SEWS, LOCK WASHER, ) ARE NOT SPECIFIED.
- 8) APPLIED 2" LENGTH OF ITEM 73 WHERE INDICATED ON ITEM 12.

- 1) LOCITE (ITEM 66) TO BE USED WHERE MECHANICAL LOCKING HARDWARE (SEWS, LOCK WASHER, ) ARE NOT SPECIFIED.
- 2) APPLIED 2" LENGTH OF ITEM 73 WHERE INDICATED ON ITEM 12.

- 1) LOCITE (ITEM 66) TO BE USED WHERE MECHANICAL LOCKING HARDWARE (SEWS, LOCK WASHER, ) ARE NOT SPECIFIED.
- 2) APPLIED 2" LENGTH OF ITEM 73 WHERE INDICATED ON ITEM 12.

- 1) LOCITE (ITEM 66) TO BE USED WHERE MECHANICAL LOCKING HARDWARE (SEWS, LOCK WASHER, ) ARE NOT SPECIFIED.
- 2) APPLIED 2" LENGTH OF ITEM 73 WHERE INDICATED ON ITEM 12.

SEE SEPARATE PARTS LIST

**RACAL Instruments, Inc.**  
 4 Cooper St., Irvine, CA 92714-1000

TITLE  
**ENCLOSURE ASSY 8 SLOT CHASSIS**

REV. NO. **407646**

SCALE 1:1

WORK NO. **B**

REV. NO. **1** OF **3**

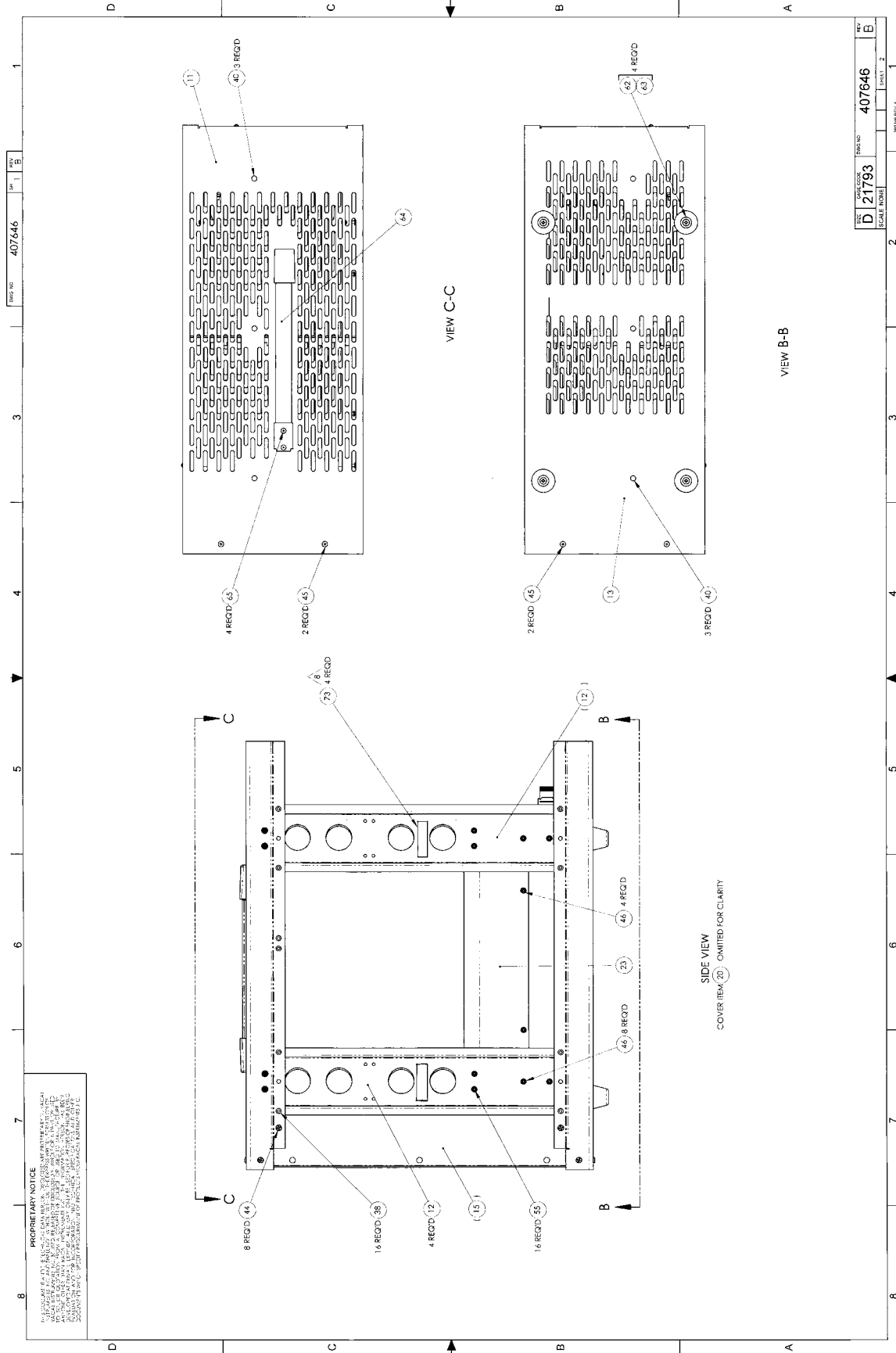

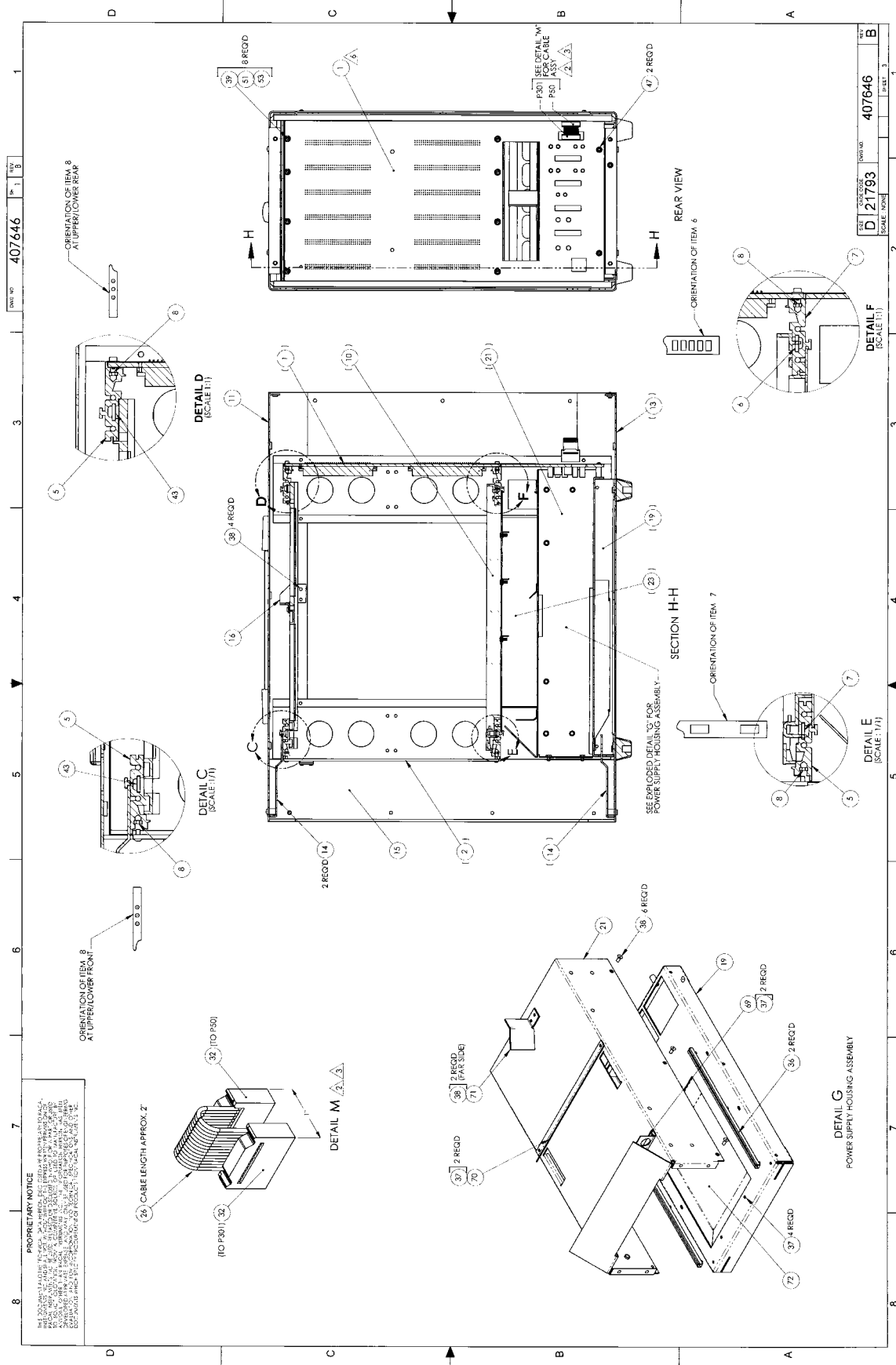

REV. NO. 407646

REV. NO. 407646

REV. NO. 407646

REV. NO. 407646

REV. NO. 407646

REV. NO. 407646

REV. NO. 407646

REV. NO. 407646

REV. NO. 407646

REV. NO. 407646

REV. NO. 407646

REV. NO. 407646

REV. NO. 407646

REV. NO. 407646

REV. NO. 407646

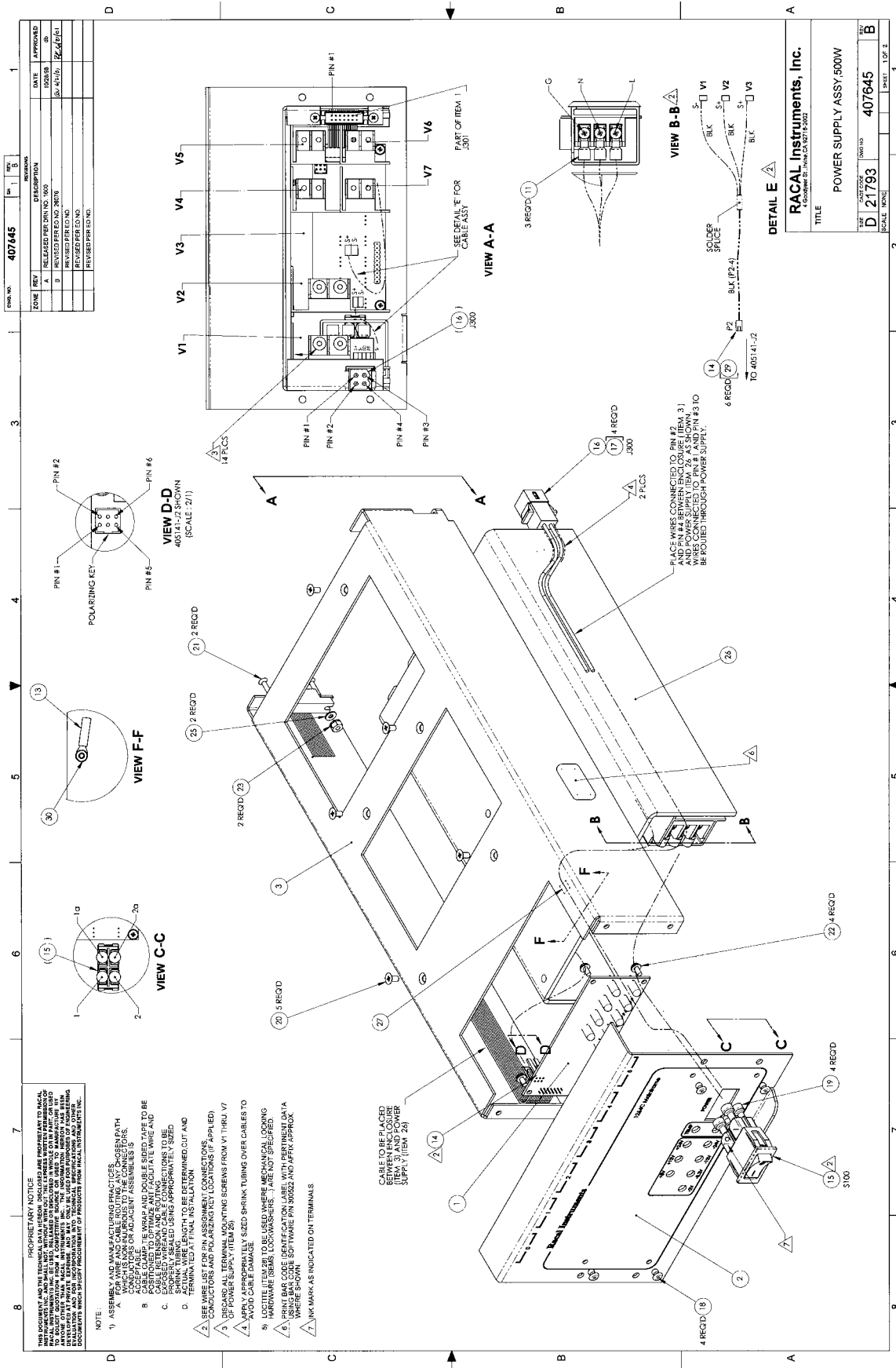

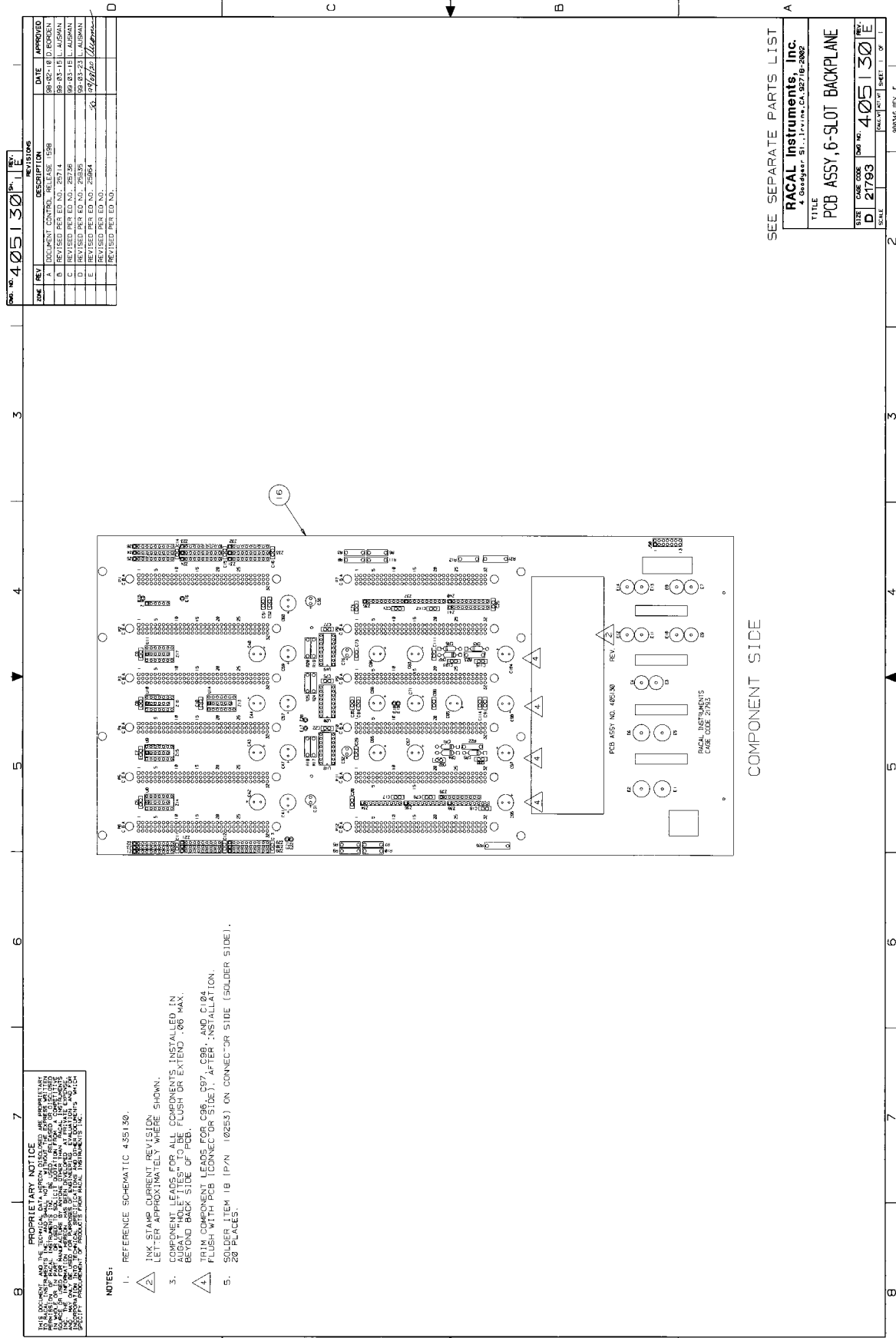

Doc. No. 4051301E

REV	DESCRIPTION	DATE	APPROVED
A	DOCUMENT CONTROL RELEASE 159H	04-02-10	D. BORDEN
B	REVISED PER ED NO. 25848	02-03-10	D. BORDEN
C	REVISED PER ED NO. 25848	02-03-10	D. BORDEN
D	REVISED PER ED NO. 25835	02-03-10	A. USMAN
E	REVISED PER ED NO. 25854	02-03-10	A. USMAN
F	REVISED PER ED NO. 25854	02-03-10	A. USMAN
G	REVISED PER ED NO. 25854	02-03-10	A. USMAN

**PROPRIETARY NOTICE**  
 THE INFORMATION CONTAINED HEREIN IS UNCLASSIFIED AND IS NOT TO BE REPRODUCED OR TRANSMITTED IN ANY FORM OR BY ANY MEANS, ELECTRONIC OR MECHANICAL, INCLUDING PHOTOCOPYING, RECORDING, OR BY ANY INFORMATION STORAGE AND RETRIEVAL SYSTEM, WITHOUT THE WRITTEN PERMISSION OF RACAL INSTRUMENTS, INC. THIS DOCUMENT IS THE PROPERTY OF RACAL INSTRUMENTS, INC. AND IS LOANED TO YOU. IT IS TO BE USED ONLY FOR THE PURPOSES SPECIFIED AND IS NOT TO BE DISTRIBUTED OUTSIDE YOUR ORGANIZATION. RETURN THIS DOCUMENT TO RACAL INSTRUMENTS, INC. WHEN YOU ARE THROUGH WITH IT.

**NOTES:**

1. REFERENCE SCHEMATIC 435130.
2. INK STAMP CURRENT REVISION LETTER APPROXIMATELY WHERE SHOWN.
3. COMPONENT LEADS FOR ALL COMPONENTS INSTALLED IN BEYOND BACK SIDE OF PCB.
4. TRIM COMPONENT LEADS FOR C95, C97, C99, AND C104 FLUSH WITH PCB (CONNECTOR SIDE), AFTER INSTALLATION.
5. SOLDER ITEM 18 (P/N 10253) ON CONNECTOR SIDE (SOLDER SIDE).

SEE SEPARATE PARTS LIST

**RACAL Instruments, Inc.**  
 4 Oneida St., Irvine, CA 92718-2002

TITLE  
**PCB ASSY, 6-SLOT BACKPLANE**

REV. 2  
 DATE 02/03/10  
 DRAWN BY 21793  
 DOC. NO. 4051301E  
 SHEET 1 OF 1  
 988346 REV. 1

<b>1</b>	<b>2</b>	<b>3</b>	<b>4</b>
DWG. NO. <b>435130</b>		SH. <b>1</b>	REV. <b>A</b>
<b>REVISIONS</b>			
<b>REV</b>	<b>DESCRIPTION</b>	<b>DATE</b>	<b>APPROVED</b>
A	DOCUMENT CONTROL RELEASE		
	REVISED PER EO NO.		
	REVISED PER EO NO.		
	REVISED PER EO NO.		

**NOTES:**

- RESISTOR VALUES ARE IN OHMS, 1/4W, ±5% UNLESS OTHERWISE SPECIFIED.
- CAPACITOR VALUES ARE IN MICROFARADS: 100V, ±20% UNLESS OTHERWISE SPECIFIED.
- RESISTOR NETWORK VALUES ARE IN OHMS, ±2%.

5130p2.sch 5130p2.sch	5130p3.sch 5130p3.sch	5130p4.sch 5130p4.sch
5130p5.sch 5130p5.sch	5130p6.sch 5130p6.sch	5130p7.sch 5130p7.sch
5130p8.sch 5130p8.sch	5130p9.sch 5130p9.sch	5130p10.sch 5130p10.sch
5130p11.sch 5130p11.sch	5130p12.sch 5130p12.sch	5130p13.sch 5130p13.sch
5130p14.sch 5130p14.sch		

<b>DEVICE TYPE</b>	<b>REFERENCE DESIGNATOR</b>	<b>POWER PINS</b>	<b>HIGHEST REF. DES.</b>
74ACT32	UB-J11,U14	GND VCC	C115
10H116	U18-U20	14 7	CR6
		1,16 8	E14
			J54
			P12
			R26
			U20
			Z11

  

**RACAL Instruments, Inc.**  
4 Goodyear St., Irvine, CA. 92618

**TITLE**  
**SCHEMATIC, 6-SLOT BACKPLANE**

<b>SIZE</b>	<b>CAGE CODE</b>	<b>DWG NO.</b>	<b>REV.</b>
<b>B</b>	<b>21793</b>	<b>435130</b>	<b>A</b>
<b>SCALE</b>	<b>NONE</b>	<b>5-Nov-1998</b>	<b>SHEET 1 OF 14</b>



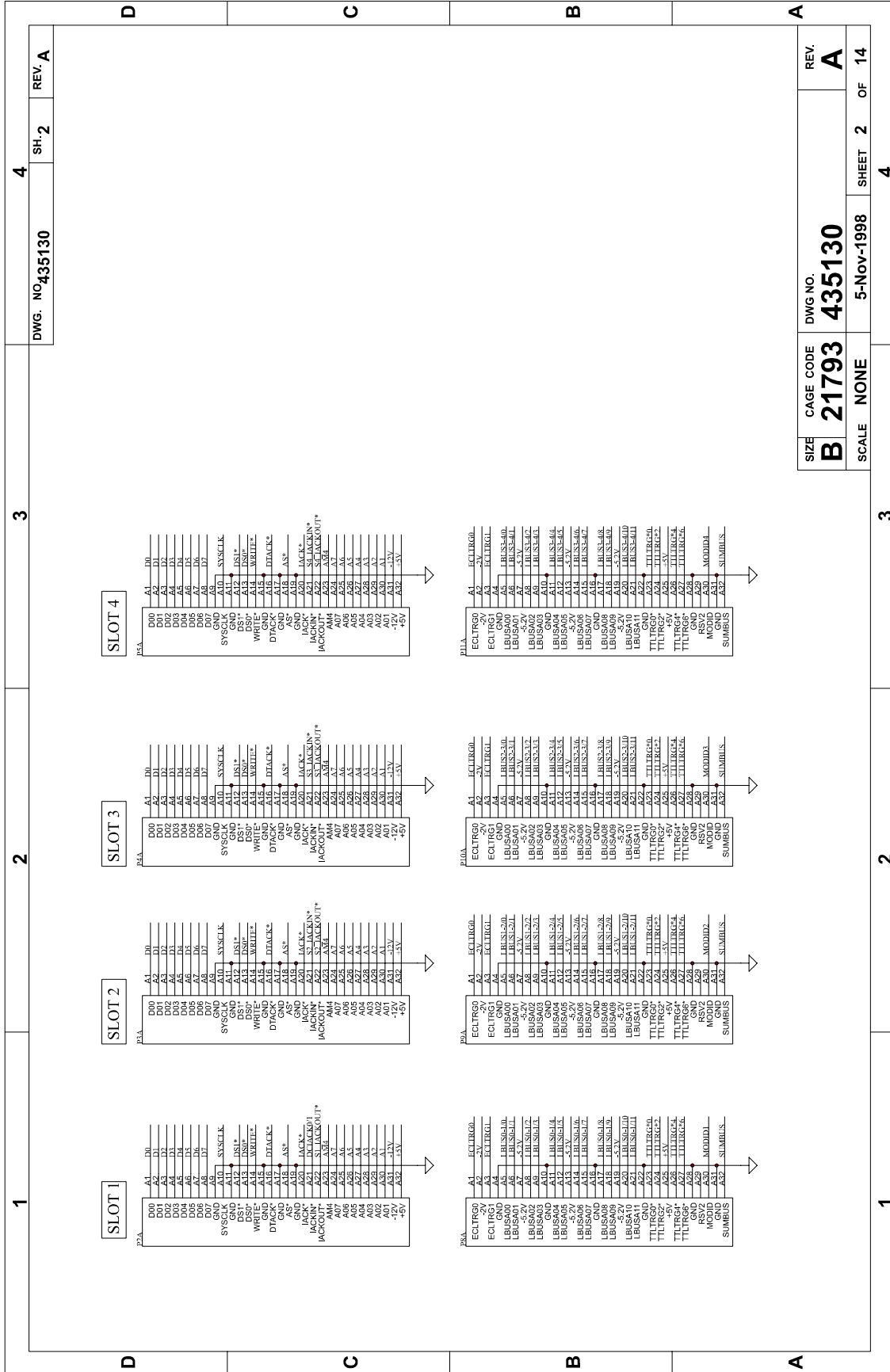

DWG. NO. 435130

4

3

2

1

REV.	A
CAGE CODE	21793
DWG NO.	435130
SCALE	NONE
SHEET	2
OF	14
SHEET NO.	4
DATE	5-Nov-1998

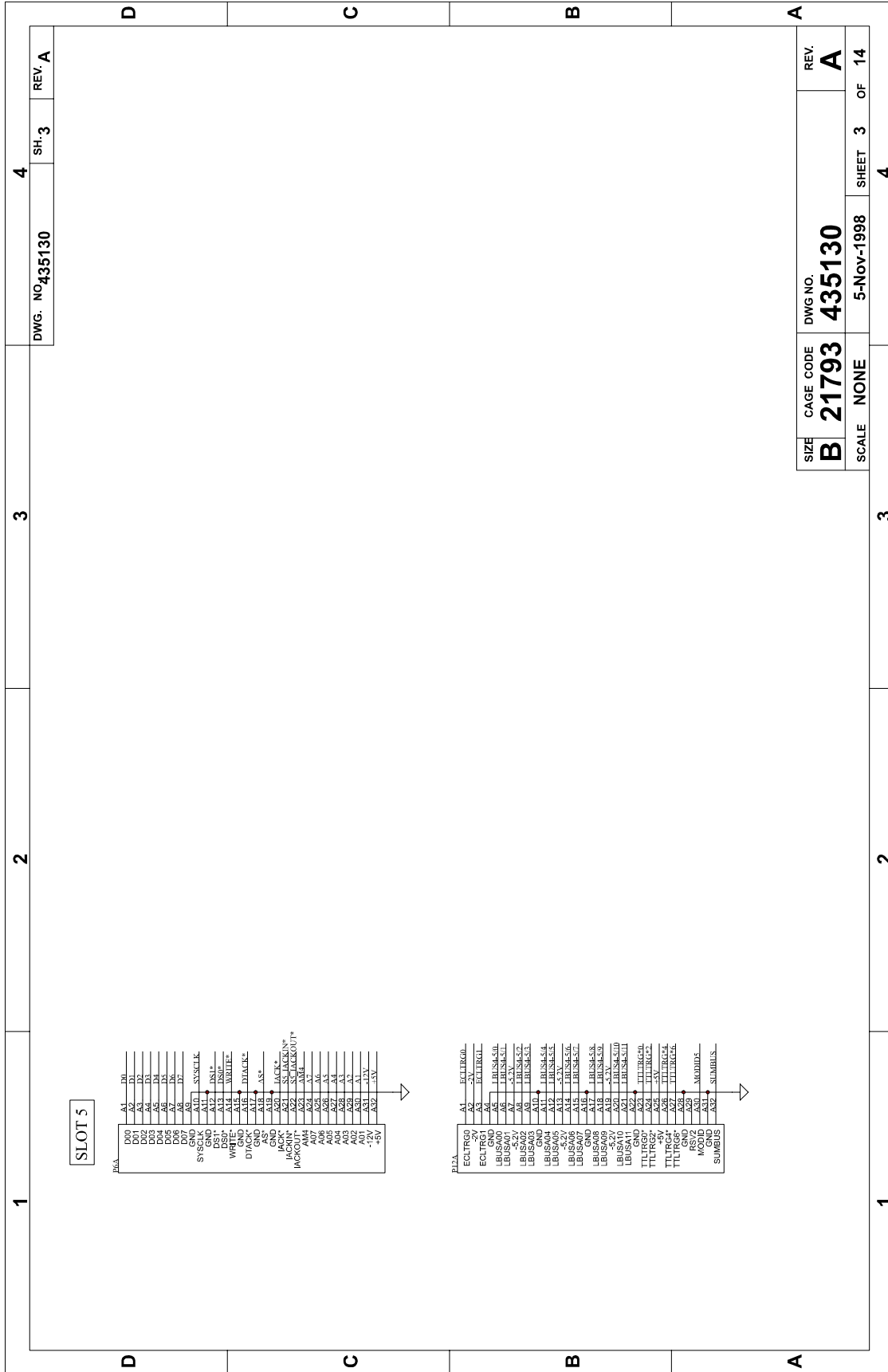

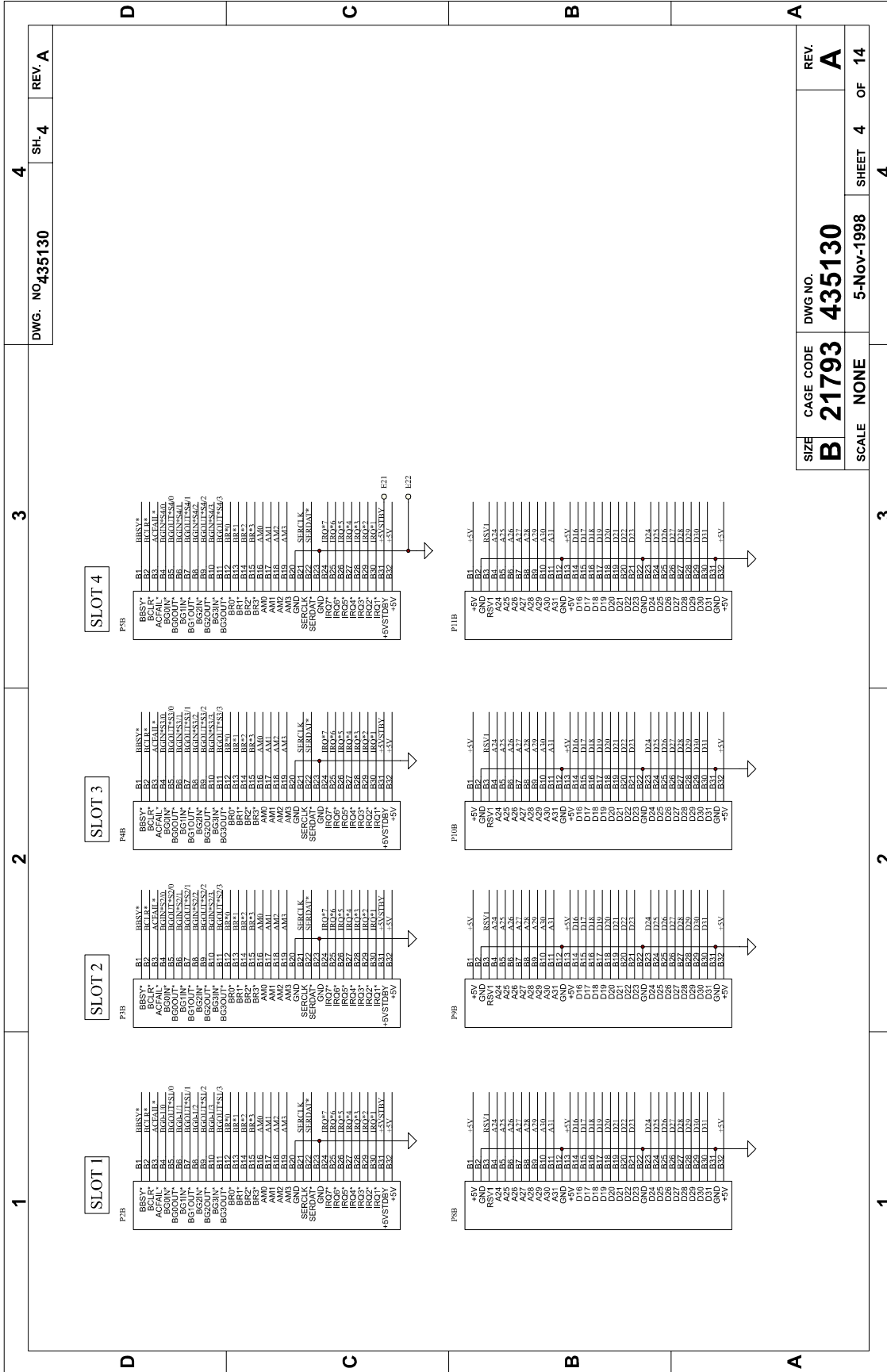

DWG. NO. 435130  
SH. 4  
REV. A

SIZE B CAGE CODE 21793 DWG NO. 435130 REV. A  
SCALE NONE SHEET 4 OF 14

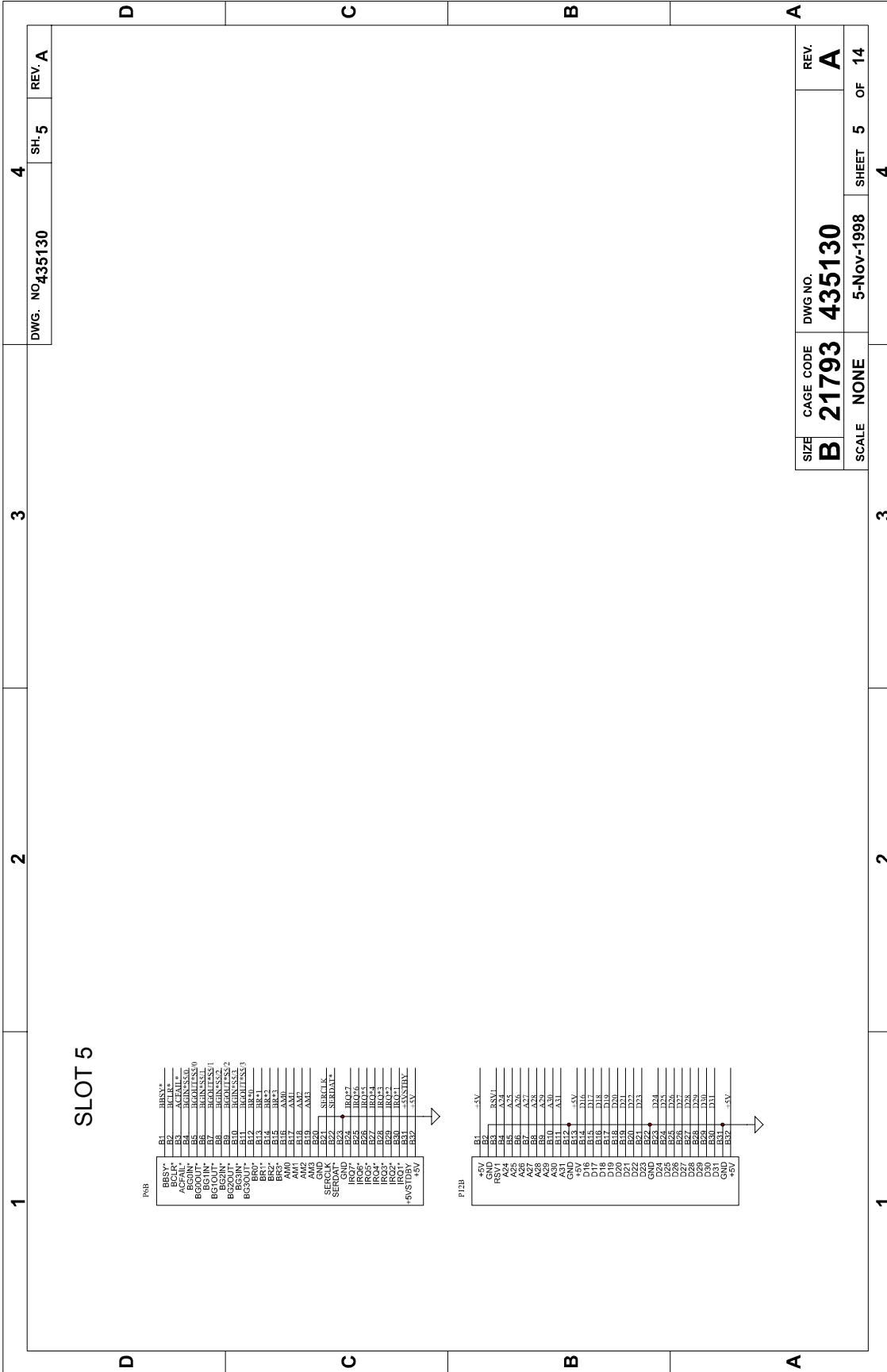



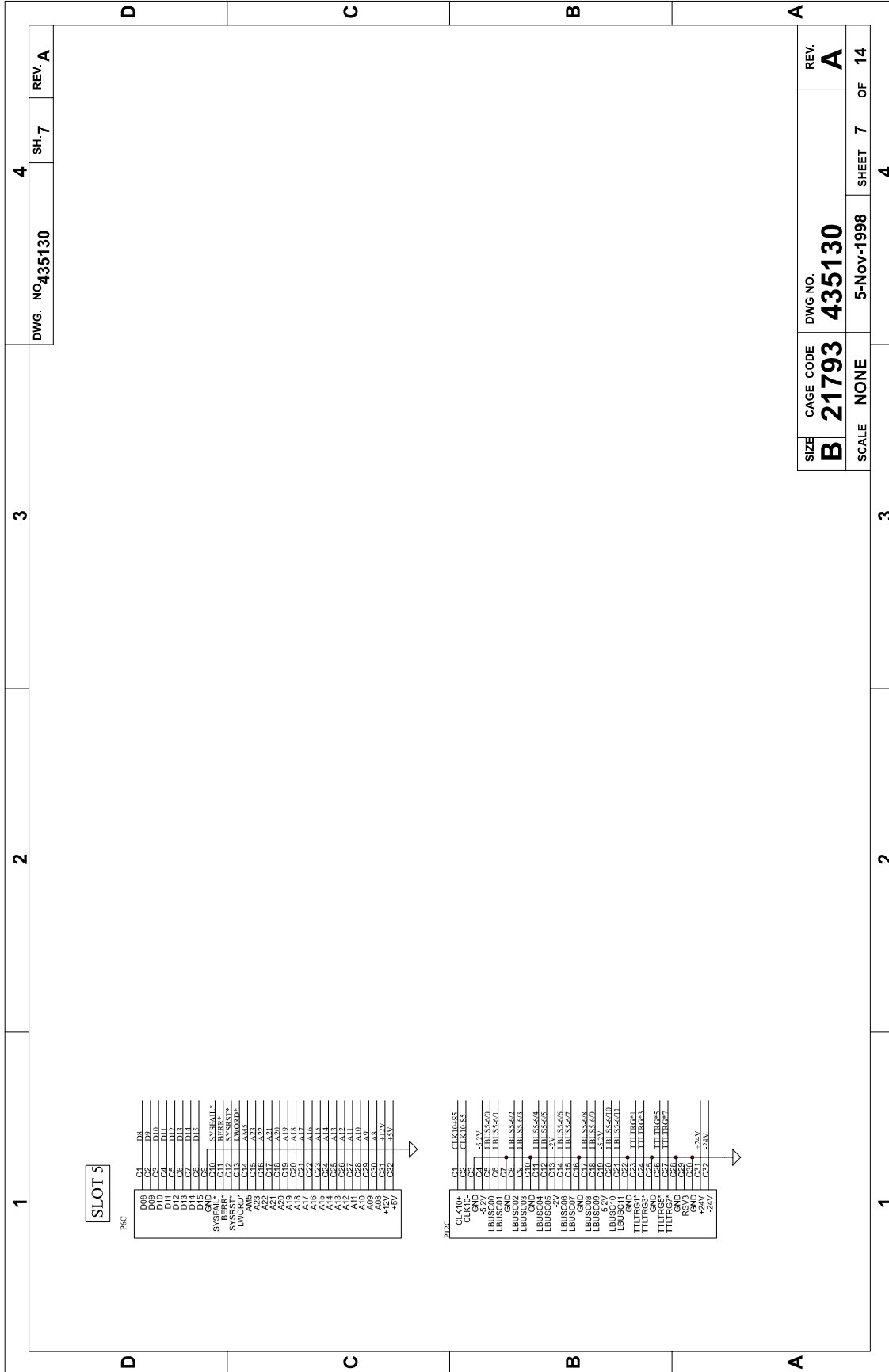



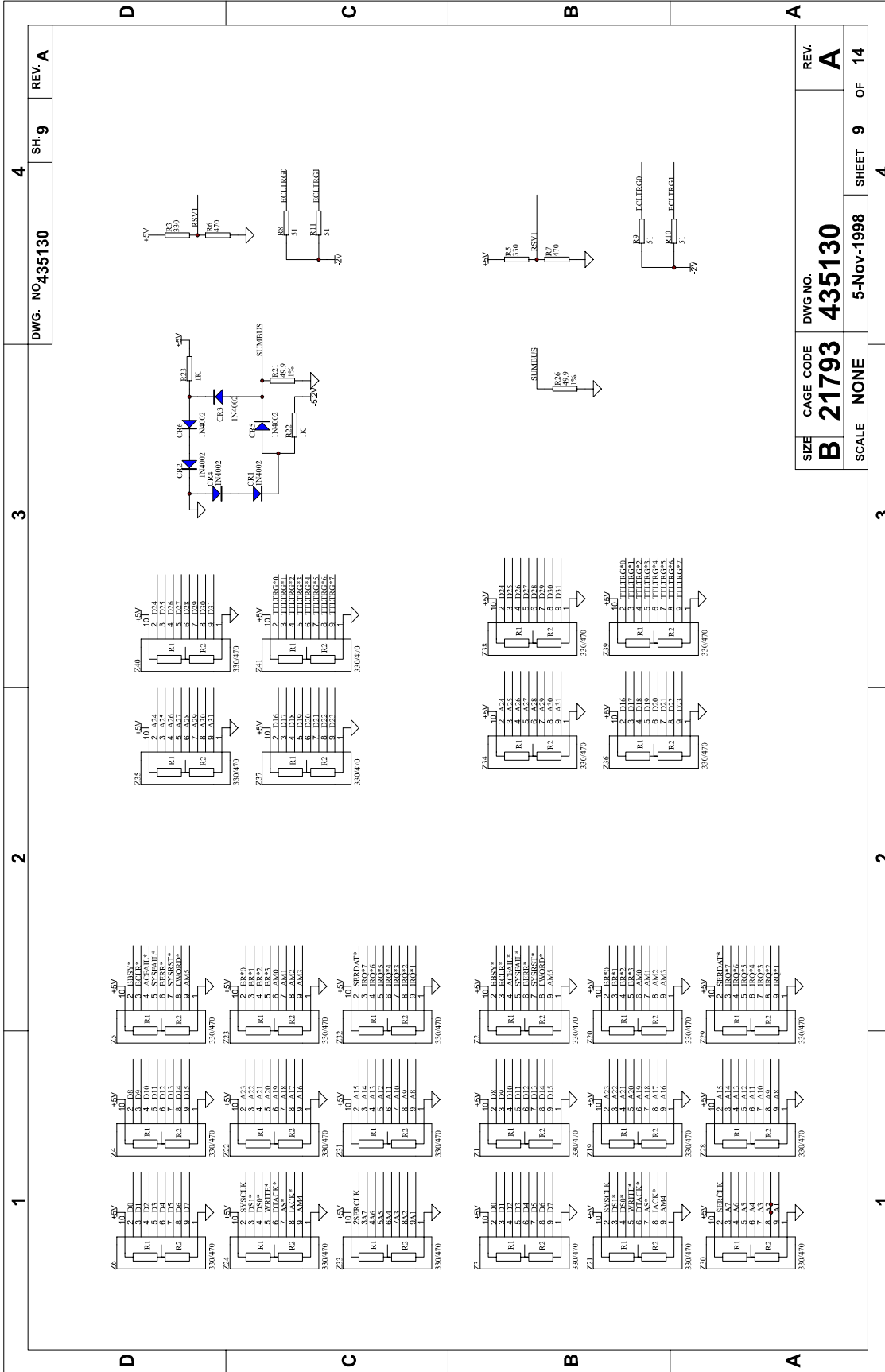

DWG. NO. 435130

SH. 9

REV. A

SIZE	CAGE CODE	DWG NO.	REV.
<b>B</b>	<b>21793</b>	<b>435130</b>	<b>A</b>
SCALE	NONE	5-Nov-1998	SHEET 9 OF 14





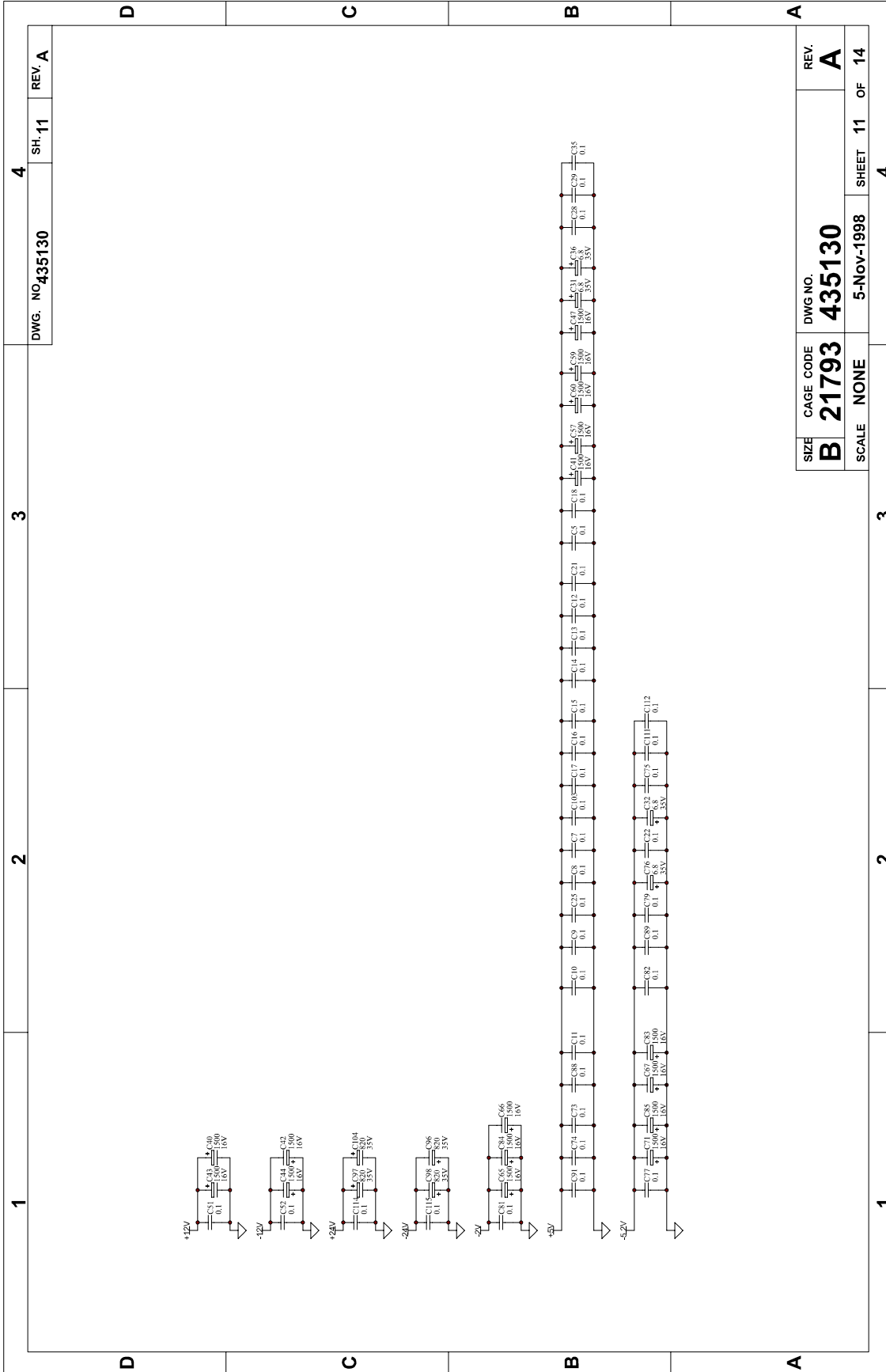

4	SH. 11	REV. A	
---	--------	--------	--

DWG. NO. 435130			
-----------------	--	--	--

SIZE	CAGE CODE	DWG. NO.	REV.
B	21793	435130	A
SCALE	NONE	5-NOV-1998	SHEET 11 OF 14

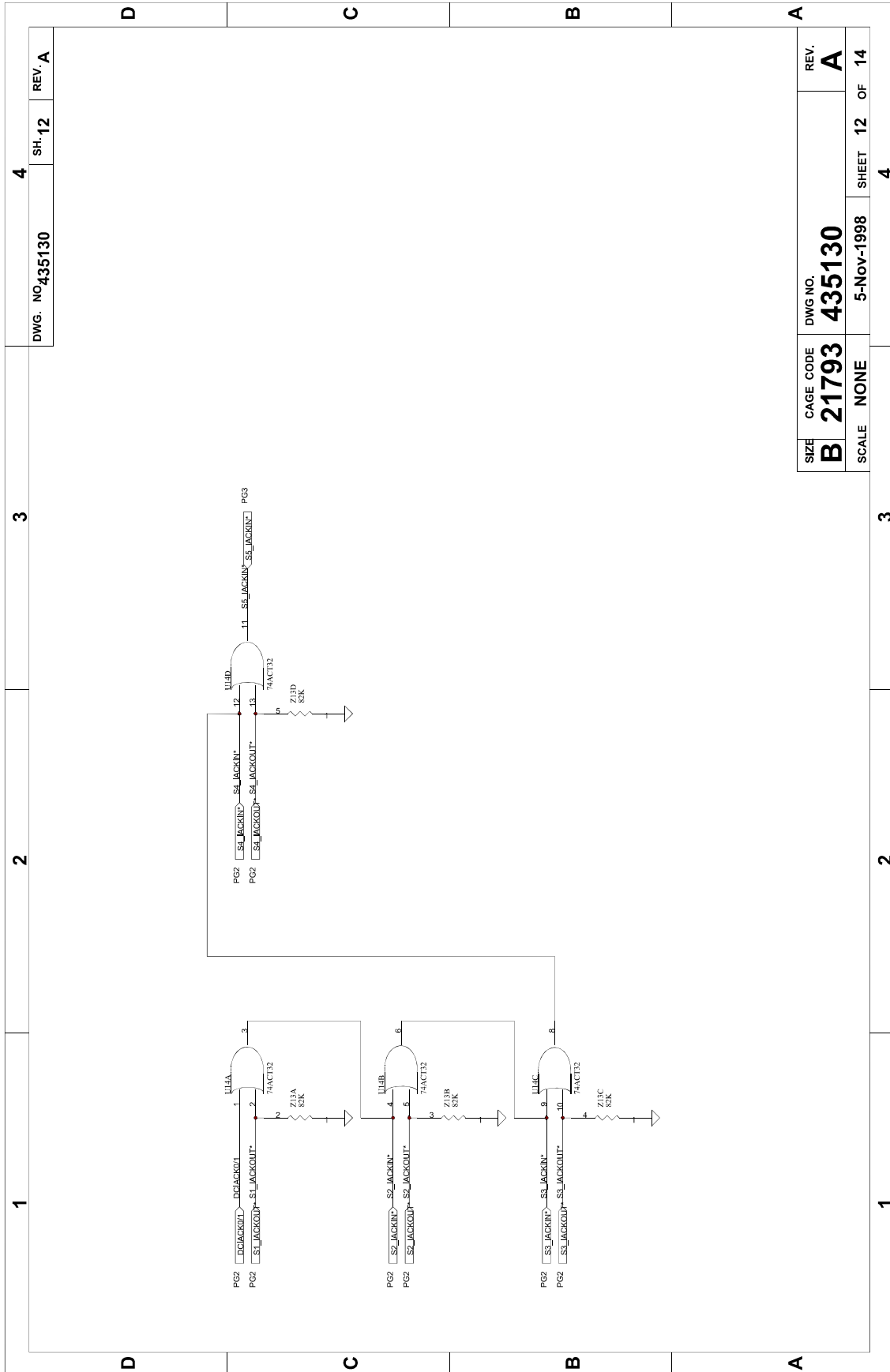

1	2	3	4
DWG. NO. 435130			SH. 12
			REV. A

SIZE	CAGE CODE	DWG NO.	REV.
B	21793	435130	A
SCALE	NONE	5-Nov-1998	SHEET 12 OF 14
			4

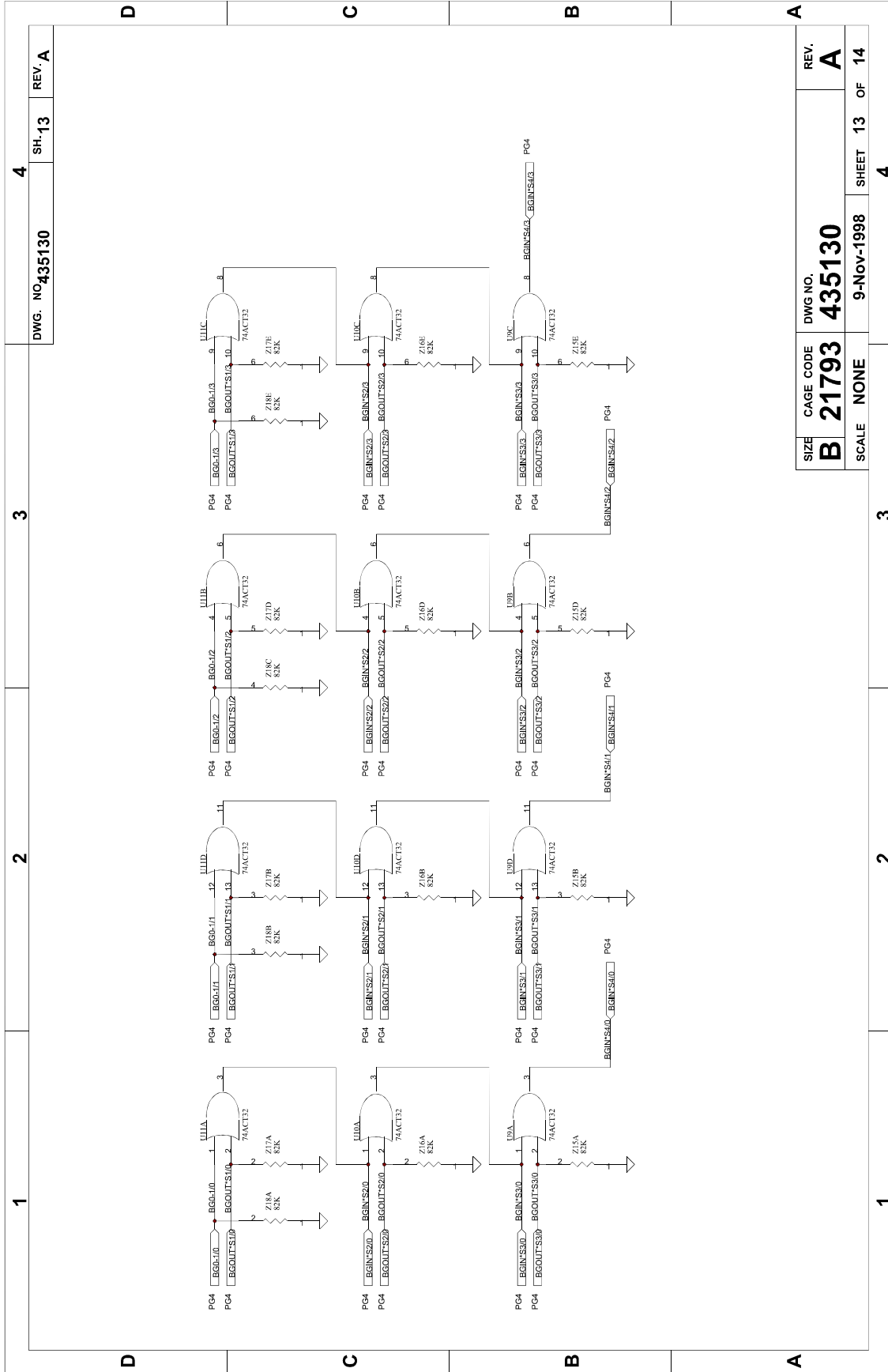

DWG. NO. 435130 SH. 13 REV. A

SIZE	CAGE CODE	DWG NO.	REV.
B	21793	435130	A
SCALE	NONE	9-Nov-1998	SHEET 13 OF 14

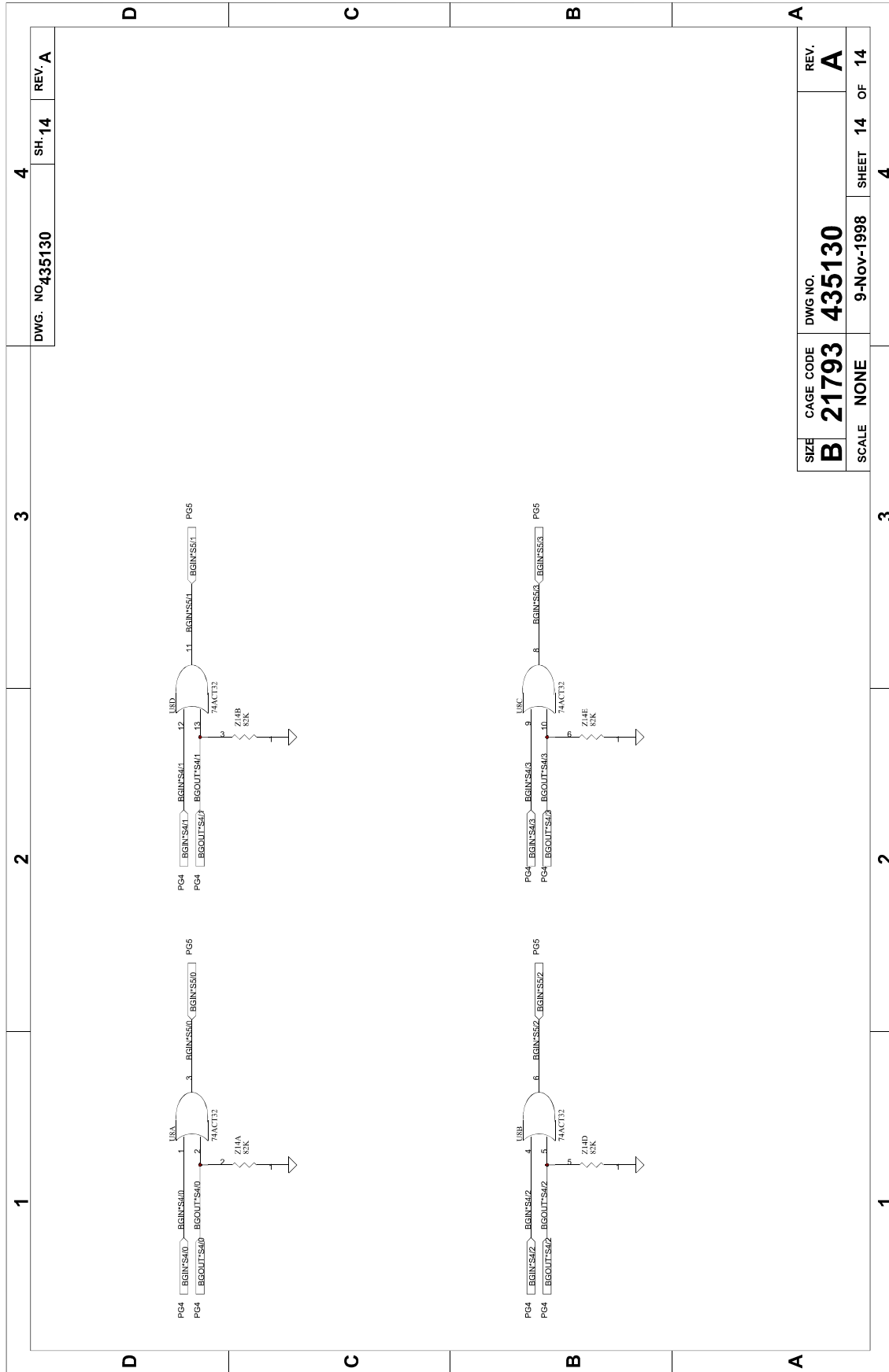

DWG. NO. 435130

SH. 14

REV. A

SIZE	CAGE CODE	DWG. NO.	REV.
<b>B</b>	<b>21793</b>	<b>435130</b>	<b>A</b>
SCALE	NONE	9-Nov-1998	SHEET 14 OF 14
		4	



<b>1</b>	<b>2</b>	<b>3</b>	<b>4</b>
		DWG. NO. 435141	
		SH. 1	
		REV. A	
<b>REVISIONS</b>			
REV	DESCRIPTION	DATE	APPROVED
A	DOCUMENT CONTROL RELEASE		
	REVISED PER EO NO.		
	REVISED PER EO NO.		
	REVISED PER EO NO.		
<b>NOTES:</b>			
1. CAPACITOR VALUES ARE IN MICROFARADS. 50V, +/-20% UNLESS OTHERWISE SPECIFIED. 2. RESISTOR VALUES ARE IN OHMS. 1% 1/8W +/-1% UNLESS OTHERWISE SPECIFIED.			
SYSTEM RESET PAGE 2 SCH			
VOLTAGE SENSOR PAGE 3 SCH			
AIR FLOW AND TEMP SENSOR PAGE 4 SCH			
<b>POWER PINS</b>			
REFERENCE DESIGNATOR	DEVICE TYPE	+5V	VCC
U1-U8	LM339	3	GND
U9-U10	LM324A	4	12
U11	LM50	1	11
		3	
<b>CONTRACT NO.</b>			
<b>APPROVALS</b>		<b>DATE</b>	
DRAWN J.ROBINSON		981108	
CHECKED D.DOOR, L.A.		981110	
ENGR T.NGO, D.DOOR		06-18-88	
QUALITY ASSURANCE:GENKUONG		11-10-88	
DESIGN ACTIVITY			
<b>APPLICATION</b>			
2			
<b>SCALE</b>			
NONE			
<b>SCALE</b>			
11-Nov-1998			
<b>SHEET</b>			
1 OF 4			
<b>4</b>			

**RACAL Instruments, Inc.**  
4 Goodyear St., Irvine, CA. 92618

**TITLE**  
**SCHEMATIC, MONITOR**

**SIZE** B  
**CAGE CODE** 21793  
**DWG NO.** 435141  
**REV.** A

CAD CURRENT REV. LTR  
FOR SHEETS 1 THRU 4  
DRAWN WITH PROTEL  
VERSION 3.2.3

**PROPRIETARY NOTICE**  
THIS DOCUMENT AND THE TECHNICAL DATA HEREON DISCLOSED ARE PROPRIETARY TO RACAL INSTRUMENTS INC. AND SHALL NOT BE REPRODUCED, COPIED, EITHER WHOLE OR IN PART, OR USED TO SOLICIT QUOTATION FROM A COMPETITIVE SOURCE ON THESE PRODUCTS UNLESS WRITTEN PERMISSION HAS BEEN OBTAINED FROM RACAL INSTRUMENTS INC. THIS NOTICE AND MAY ONLY BE USED FOR PURPOSES OF ENGINEERING EVALUATION AND FOR SPECIFY PROCUREMENT OF PRODUCTS FROM RACAL INSTRUMENTS INC.

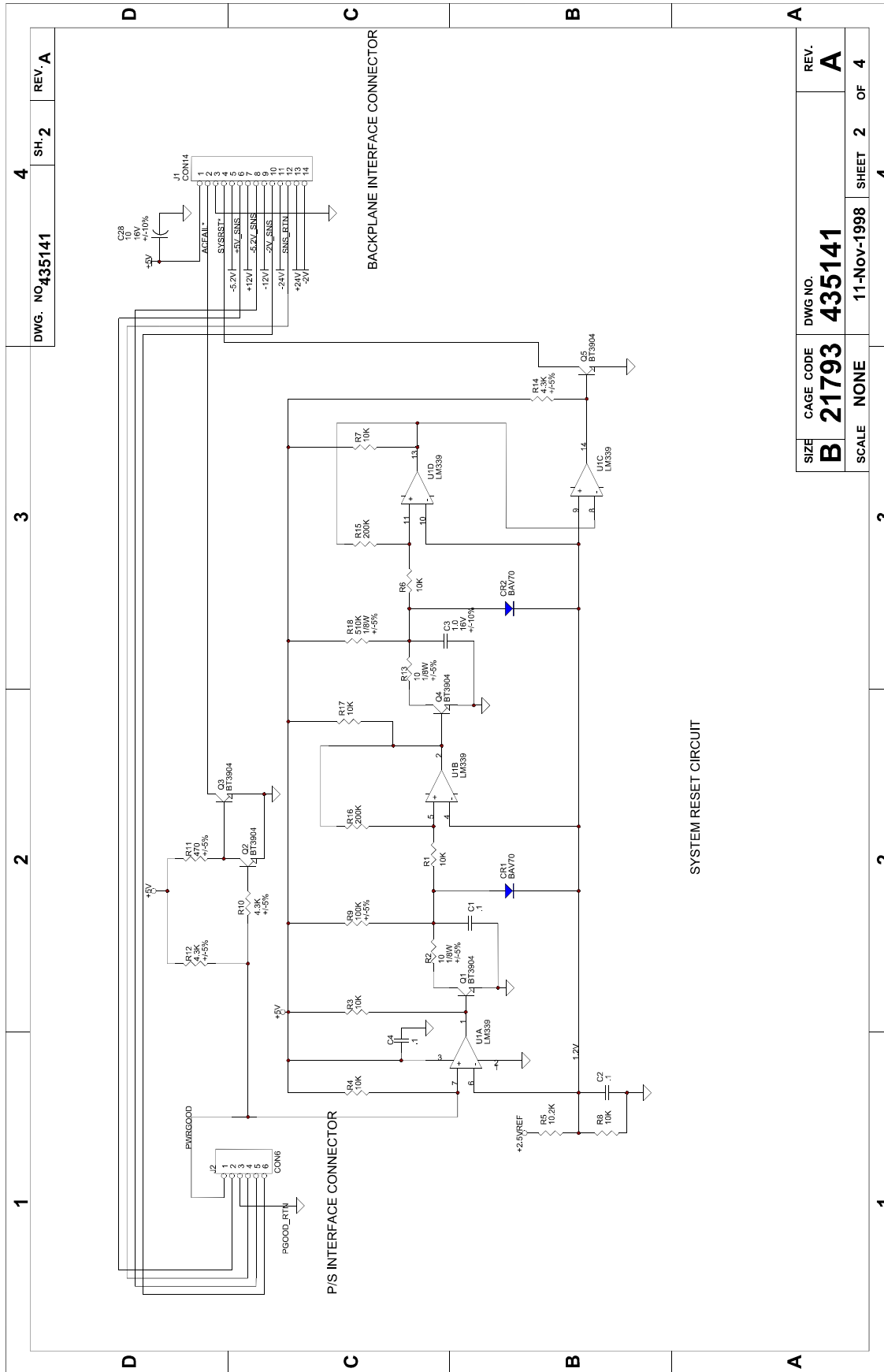

DWG. NO. 435141

3

2

1

4

SH. 2

REV. A

SIZE	CAGE CODE	DWG NO.	REV.
<b>B</b>	<b>21793</b>	<b>435141</b>	<b>A</b>
SCALE	NONE	11-Nov-1998	SHEET 2 OF 4

4

3

2

1



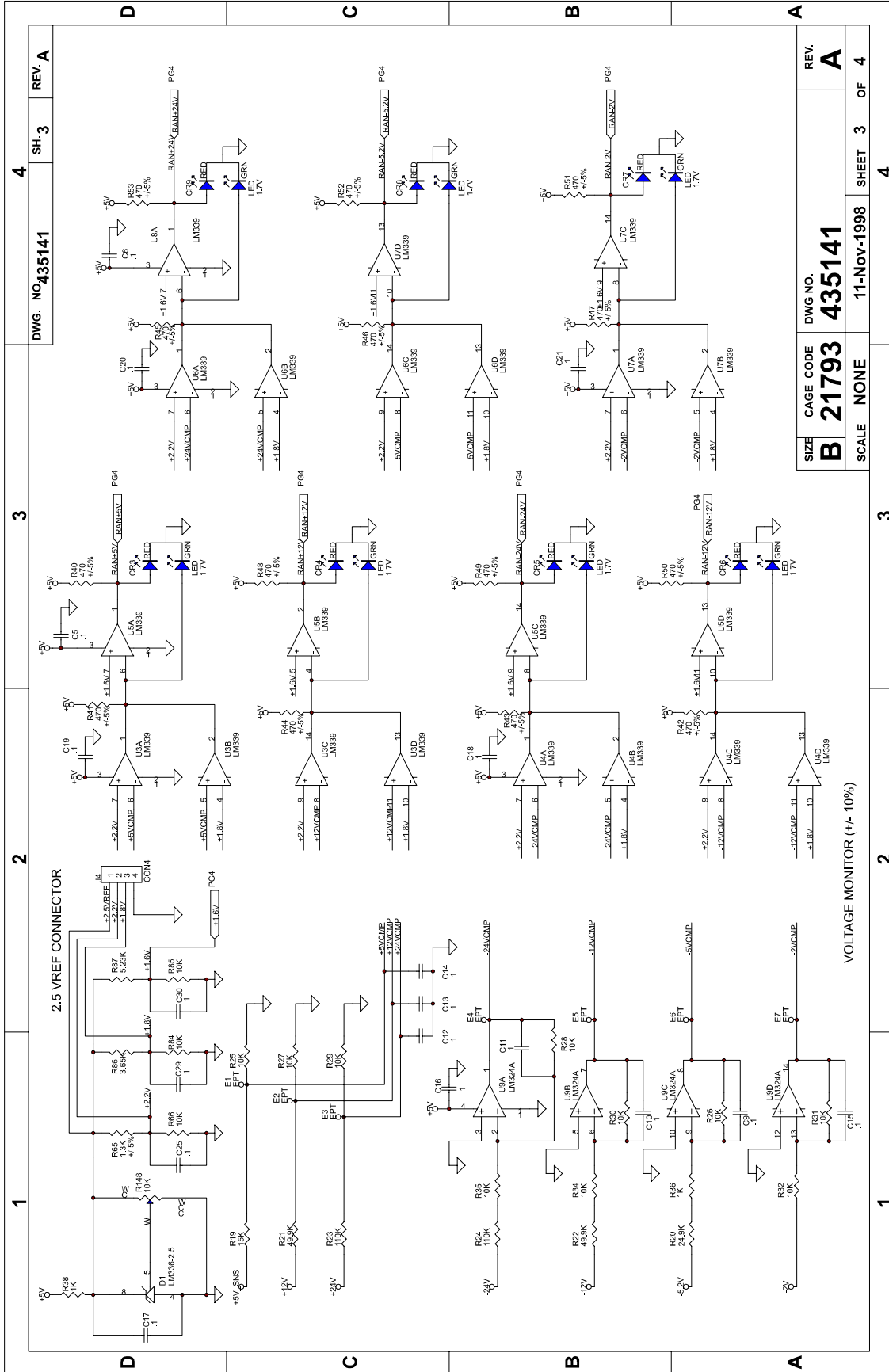

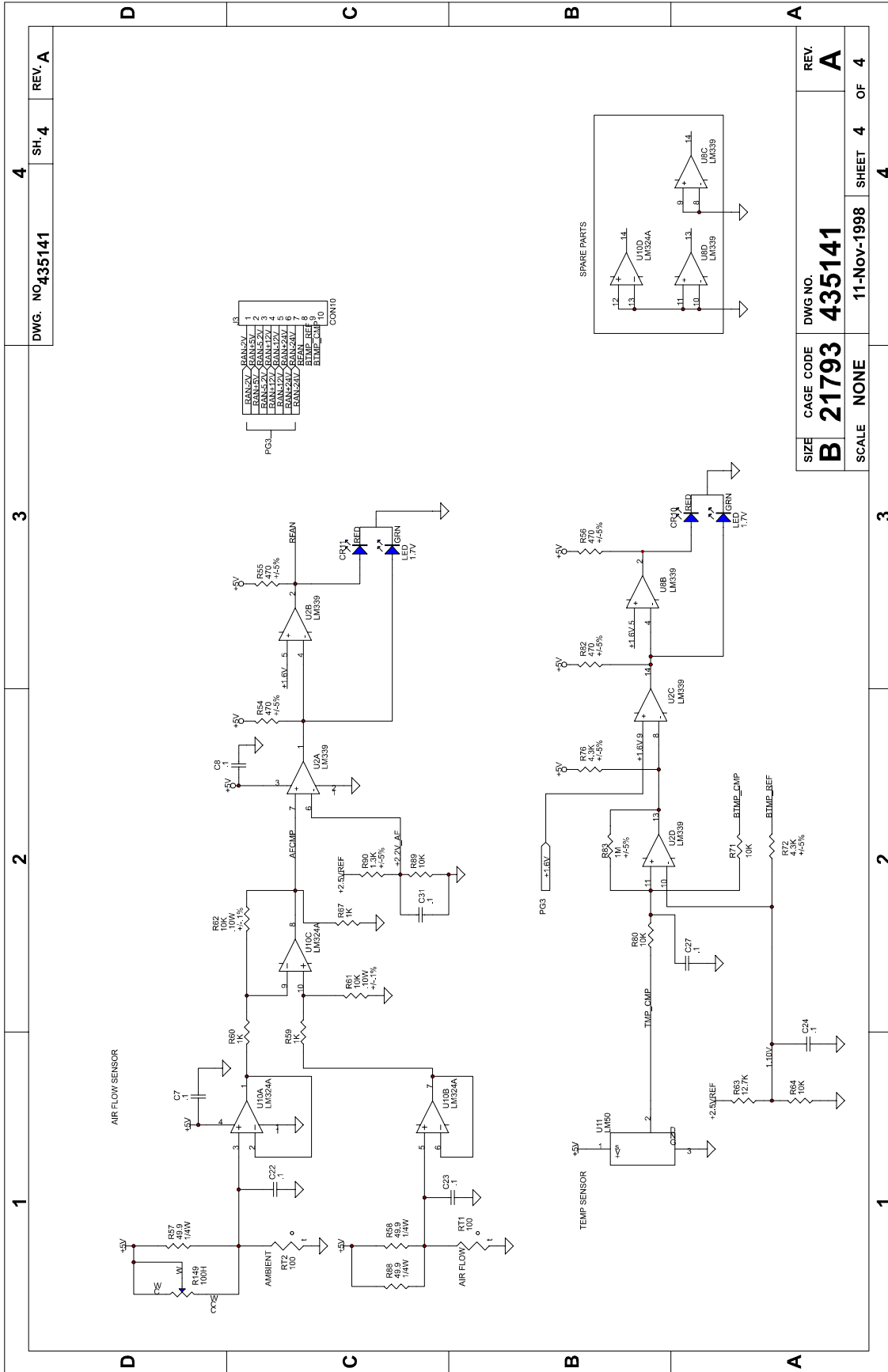

DWG. NO. 435141

SH. 4

REV. A

SIZE B CAGE CODE 21793 DWG NO. 435141 REV. A  
 SCALE NONE SHEET 4 OF 4

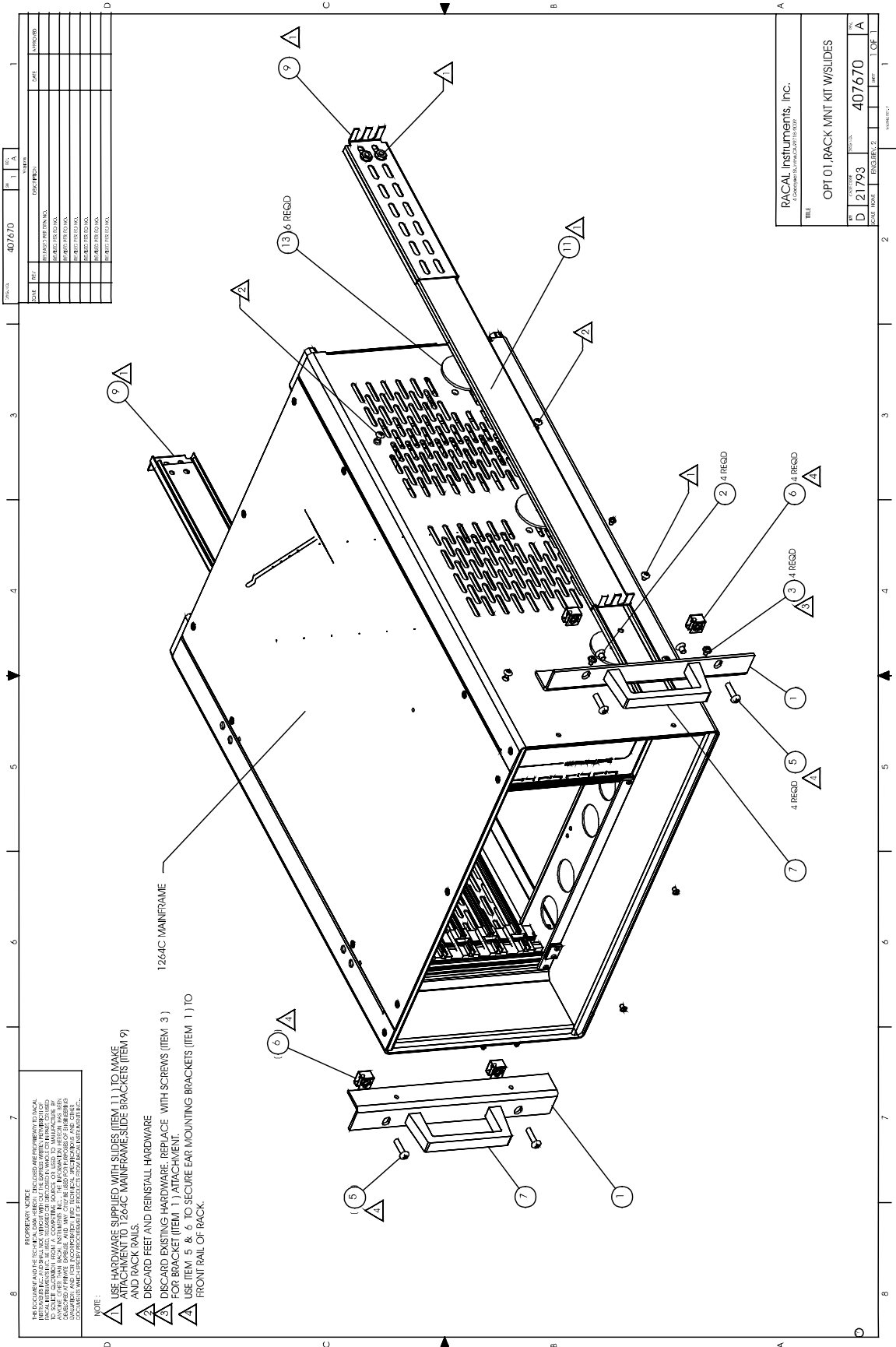

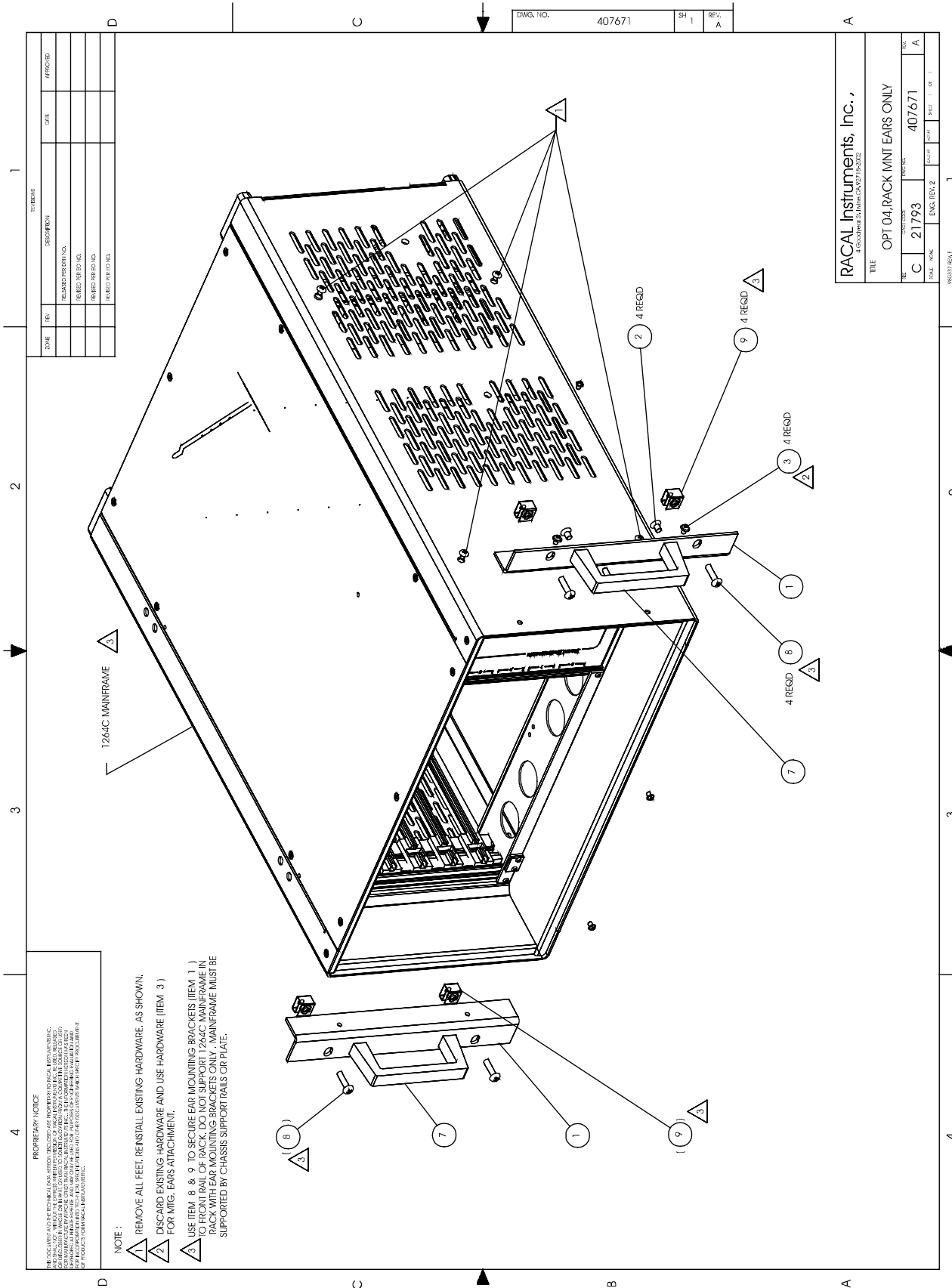

ZONE	REV.	DESCRIPTION	DATE	APPROVED
		RELEASE PERIOD NO.		
		RELEASE PERIOD NO.		
		RELEASE PERIOD NO.		
		RELEASE PERIOD NO.		

DWG. NO.	407671	SH	1	REV.	A
----------	--------	----	---	------	---

RACAL Instruments, Inc.,			
4 FOUGHER ST. BIRKENHEAD, ENGLAND			
TITLE OPT 04, RACK MINT EARS ONLY			
REV.	DATE	BY	CHKD
C	21/793	ENG. REV. 2	407671
A			

**PROPERTY NOTICE**  
 THE LOCATION AND THE RETURN ADDRESS OF RACAL INSTRUMENTS, INC. IS SUBJECT TO CHANGE WITHOUT NOTICE. RACAL INSTRUMENTS, INC. IS NOT RESPONSIBLE FOR THE LOSS OF THIS MANUAL. THE USER OF THIS MANUAL SHALL BE RESPONSIBLE FOR THE PROTECTION OF THIS MANUAL. THE USER SHALL NOT REPRODUCE OR TRANSMIT THIS MANUAL IN ANY FORM OR BY ANY MEANS, ELECTRONIC OR MECHANICAL, INCLUDING PHOTOCOPYING, RECORDING, OR BY ANY INFORMATION STORAGE AND RETRIEVAL SYSTEM. THE USER SHALL NOT REPRODUCE OR TRANSMIT THIS MANUAL IN ANY FORM OR BY ANY MEANS, ELECTRONIC OR MECHANICAL, INCLUDING PHOTOCOPYING, RECORDING, OR BY ANY INFORMATION STORAGE AND RETRIEVAL SYSTEM. THE USER SHALL NOT REPRODUCE OR TRANSMIT THIS MANUAL IN ANY FORM OR BY ANY MEANS, ELECTRONIC OR MECHANICAL, INCLUDING PHOTOCOPYING, RECORDING, OR BY ANY INFORMATION STORAGE AND RETRIEVAL SYSTEM.

**NOTE:**  
 1 REMOVE ALL FEET. REINSTALL EXISTING HARDWARE, AS SHOWN.  
 2 DISCARD EXISTING HARDWARE AND USE HARDWARE (ITEM 3) FOR MTG. EARS ATTACHMENT.  
 3 USE ITEM 8 & 9 TO SECURE EAR MOUNTING BRACKETS (ITEM 1) TO FRONT RAIL OF RACK. DO NOT SUPPORT 1264C MAINFRAME IN REAR. THE 1264C MAINFRAME MUST BE SUPPORTED BY CHASSIS SUPPORT RAILS OR PLATE.

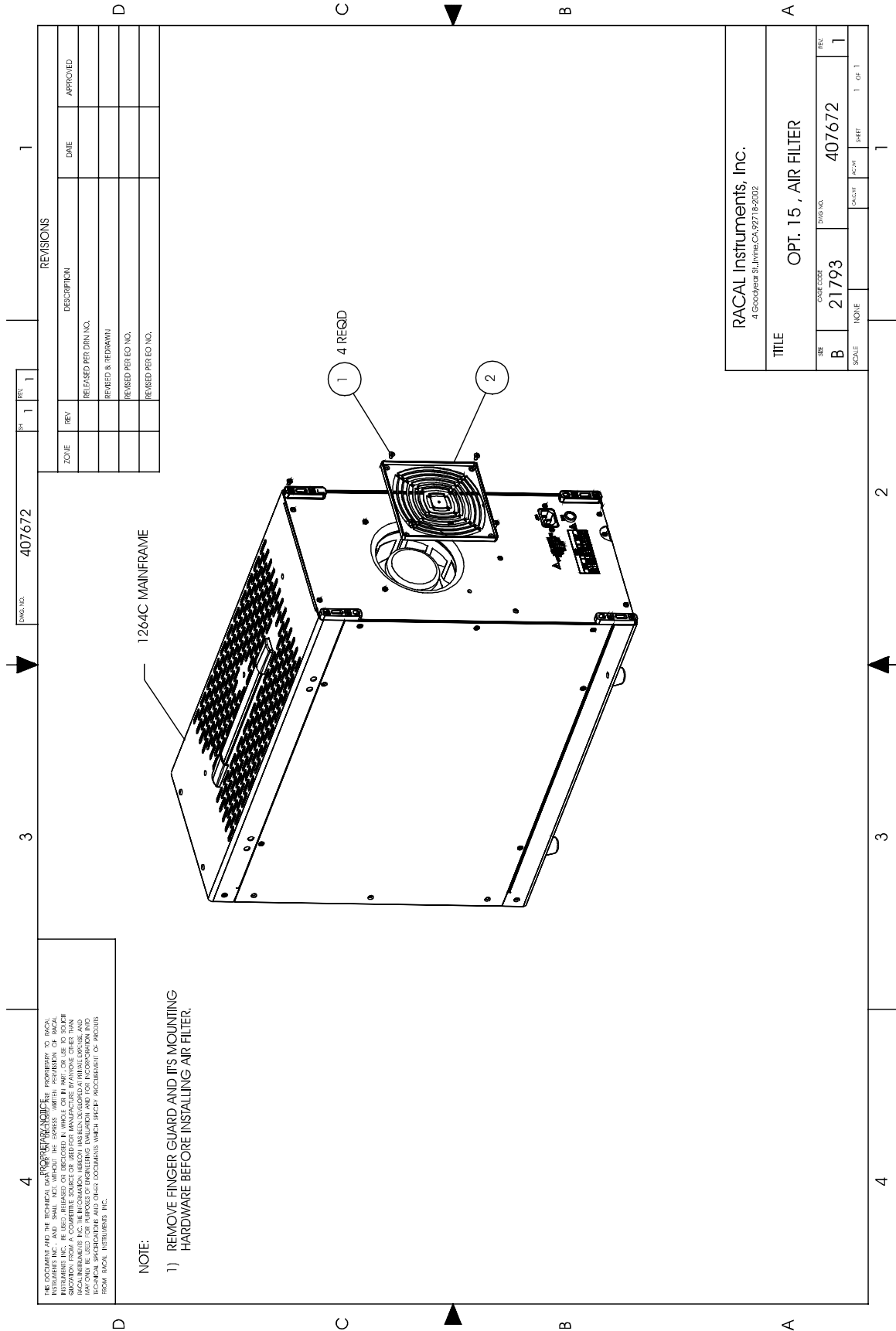

THIS DOCUMENT AND THE TECHNICAL DATA CONTAINED HEREIN ARE PROPRIETARY TO RACAL INSTRUMENTS, INC. AND ARE UNCLASSIFIED AND CONTROLLED UNDER EXECUTIVE ORDER 12812. IT IS RELEASED ON REQUEST BY RACAL INSTRUMENTS, INC. IN THIS RELEASED STATE IT IS UNCLASSIFIED EXCEPT WHERE SHOWN OTHERWISE. IT IS THE POLICY OF RACAL INSTRUMENTS, INC. TO MAKE AVAILABLE TO THE PUBLIC INFORMATION THAT IS NOT UNCLASSIFIED AND CONTROLLED UNDER EXECUTIVE ORDER 12812. IT IS THE POLICY OF RACAL INSTRUMENTS, INC. TO MAKE AVAILABLE TO THE PUBLIC INFORMATION THAT IS NOT UNCLASSIFIED AND CONTROLLED UNDER EXECUTIVE ORDER 12812. IT IS THE POLICY OF RACAL INSTRUMENTS, INC. TO MAKE AVAILABLE TO THE PUBLIC INFORMATION THAT IS NOT UNCLASSIFIED AND CONTROLLED UNDER EXECUTIVE ORDER 12812.

**NOTE:**  
 1) REMOVE FINGER GUARD AND ITS MOUNTING HARDWARE BEFORE INSTALLING AIR FILTER.

REV		REV		REV	
ZONE	REV	DESCRIPTION	DATE	APPROVED	
		RELEASED PER DRN NO.			
		REVISED & RE-DRAWN			
		REVISED PER CO. NO.			
		REVISED PER CO. NO.			

RACAL Instruments, Inc. 4 Goodspeed St., Irvine, CA 92718-2002					
TITLE OPT. 15, AIR FILTER					
REV	DATE/ISSUE	DRG. NO.	SCALE	QUANTITY	REV.
B	21793	407672		1	1
				1 of 1	

## Parts List

407647	1264C, Top Assembly.....	5-45
407646	1264C, Enclosure.....	5-46
407645	1264C, Power Supply .....	5-47
405130	PCB Assembly, 6-Slot Backplane .....	5-48
405141	PCB Assembly, Monitor .....	5-49
407699	Conn Assembly, 50 Pin Low Profile .....	5-50

Assembly 407647  
Description 1264C, 6-SLOT 500W MAINFRAME -N  
EA

Low Level Code 03  
Revision Date 2001-10-18  
Revision J

#	Component	Description	UM	Qty Reqd
1	407645	POWER SUPPLY ASSY, 500W	EA	1.000
2	407646	ENCLOSURE ASSY, 6-SLOT CHAS	EA	1.000
3	600620	CABLE, POWER AC LINE	EA	1.000
4	615064	S1M-PPANH006-32X.875	EA	10.000
5	615093	S1M-PPANH010-32X.750	EA	4.000
6	616251	S3M-PPANH004-40X.250	EA	4.000
7	610873	WASH FL NAS620C6L	EA	10.000
8	610875	WASH FL NAS620C10L	EA	4.000
9	617128	W1S006.239D.025T.141	EA	10.000
10	617130	W1S010.323D.040T.194	EA	4.000
11	980827	MANUAL, USER, 1264C	EA	1.000
12	456533	FOOT, REAR	EA	4.000
13	456647-001	PANEL, REAR, 1264C	EA	1.000
14	456651	PANEL, AIR DEFLECTOR	EA	1.000
15	456653-001	ENCLOSURE, IMPELLER MTG	EA	1.000
16	602339-104	CON-PWR-RCP004C.198D	EA	1.000
17	602341-001	TRMCRP-SNP-U-F20-14G	EA	4.000
18	611469	RVT-PP-DOM.250DX.275.063-.13	EA	3.000
19	615059	S1M-PPANH006-32X.375	EA	8.000
20	615556	S1M-PFL1H006-32X.250	EA	12.000
21	616256	S3M-PPANH006-32X.375	EA	7.000
22	616342	S1MPPAN-M4.0X0.70X08	EA	2.000
23	617167-003	NT5HEX006-32STL-ZINC	EA	2.000
24	616254	S3M-PPANH004-40X.500	EA	2.000
25	617129	W1S008.280D.031T.168	EA	2.000
26	921590	GUARD, FAN, 172MM	EA	1.000
27	921588	IMPELLER, 115VAC, 320CFM	EA	1.000
28	600961	CLP-CA-STD.190D-ADBK	EA	1.000
29	921163-015	FUSE-15AMP-SLO BLO	EA	1.000
30	921257	FUSEHOLDER, 3AG LOW PROFILE	EA	1.000
31	921496	FILTER, EMI, PWR ENTRY, AC, 15A	EA	1.000
32	617167-006	NT5KPS006-32STL-ZINC 6-32SP	EA	1.000
33	602307	SPLICE, BUTT, INS16-14G	EA	1.000
34	611417	CLP-CA-STD.180D-ADBK-NO-WH	EA	1.000
35	610388	GROMMET, CATERPILLAR	EA	1.000
36	500009	TBGSRK-POF.125ID-BLACK	FT	
37	601509	TRMCRP-RNG006S16-14G	EA	6.000
38	521111	WRTEF-STR16G-1-1-1 BRN	FT	
39	521666	WRTEF-STR16G-6-6-6 BLU	FT	
40	522000	WRTEF-STR18G-0-0-0 BLK	FT	
41	522999	WRTEF-STR18G-9-9-9-WHT	FT	
42	456271	COVER, CARD GUIDE, MOLDED	EA	3.000
43	611476	CLAMP, OVAL CAPACITOR	EA	1.000
44	120361	CPPP3-0003.0U0370V10	EA	1.000
45	601364	TRMCRP-SPD006S22-18G	EA	4.000
46	920962	LOCTITE-242-MED STR	EA	
47	130195	CPCD3-0000.1U0100V20	EA	4.000
48	601698	TRMSDR-RNG-04S1H.020	EA	4.000
49	500143	TBGSRK-POF.062ID-BLACK	FT	
50	020755	RSWW1-070.00H010W005	EA	2.000
51	500334	WRBCT-SLD14G-X-X-X	EA	
52	617167-005	NT5KPS004-40STL-ZINC	EA	8.000
53	020737-043	RSWW1-068.00H050W001	EA	3.000
54	602515	SWITCH,115/230V,DPDT	EA	1.000
55	616253	S3M-PPANH004-40X.375	EA	6.000

Assembly 407646  
Description ENCLOSURE ASSY, 6-SLOT CHAS -D  
EA

Low Level Code 04  
Revision Date 1999-06-29  
Revision B

#	Component	Description	UM	Qty Reqd
1	405130	PCB ASSY, 6-SLOT BACKPLANE	EA	1.000
2	456693	FILLER PANEL, LEFT, 6-SLOT	EA	1.000
3	456694	KEY, LOCKOUT, 6 SLOT	EA	2.000
4	456339	CARD GUIDE, TOP	EA	6.000
5	456412-003	RAIL, CDG MTG, FRNT/REAR, VXI	EA	3.000
6	456462	PUNCH STRIP, CDG MTG, 6 SLOTS	EA	1.000
7	456463	STRIP, CDG MTG, 6 SLOTS	EA	1.000
8	456464	RAIL NUT, 6 SLOTS	EA	4.000
10	456631	CARD GUIDE, SKIRTED, 4-PORT	EA	6.000
11	456634	COVER, TOP	EA	1.000
12	456635	SUPPORT, CD EXT.MTG	EA	4.000
13	456641	COVER, BOTTOM	EA	1.000
14	456642	TRIM, FRONT	EA	2.000
15	456643	TRIM, FRONT, SIDE	EA	2.000
16	456645	SUPPORT, TOP CARD GUIDE	EA	1.000
17	456646	EXTRUSION, BACKPLANE MTG, BOT	EA	1.000
19	456648	PANEL, PWR ASSY SUPPORT	EA	1.000
20	456649	COVER, SIDE	EA	2.000
21	456650	PANEL, AIR DUCT, LOWER	EA	1.000
23	456652	PANEL, AIR REGULATOR	EA	1.000
26	500329	CAFT-RBN-14C28G-1STR	EA	
32	602240	CON-FCA-RCP014I.100D	EA	2.000
36	611161	CARD GUIDE-8.00 INCH	EA	2.000
37	611173	RVT-PP-PAN.250DX.337	EA	8.000
38	611359	RVT-PP-F1C.226DX.337	EA	28.000
39	611390	S1MHSTR-M2.5X0.45x12	EA	8.000
40	611393	RVT-SN-RND.320DX.280.138.177	EA	6.000
41	615015	S1M-PPANH002-56X.312	EA	2.000
43	456518	STRIP, CDG MTG, 6 SLOTS, UPPER	EA	2.000
44	615556	S1M-PFL1H006-32X.250	EA	18.000
45	615800-602	S1M-HBTNH006-32X.250	EA	4.000
46	616255	S3M-PPANH006-32X.312	EA	12.000
47	616256	S3M-PPANH006-32X.375	EA	3.000
48	616304	S1MPPAN-M2.5X0.45X10	EA	2.000
51	617102	W1F004.281D.025T.119	EA	8.000
53	617127	W1S004.202D.020T.115	EA	10.000
55	618112	S1F-PPANH006-20X.500	EA	16.000
62	921027	BUMPER-FOOT	EA	4.000
63	616262	S3M-PPANH008-32X.625	EA	4.000
64	921556	HANDLE, CHASSIS, 9" LONG	EA	1.000
65	611434	RVT-PP-DOM.250DX.400.188-.25	EA	4.000
66	920962	LOCTITE-242-MED STR	EA	
69	456696	DEFLECTOR, FRONT, AIR CHAMBER	EA	1.000
70	456697	DEFLECTOR, CENTER, AIR CHAMBER	EA	1.000
71	456698-001	DEFLECTOR, AIR	EA	1.000
72	456699	BAFFLE, AIR, P/S ENCLOSURE	EA	1.000
73	910635	SPONGE, PRESSURE, SENSITIVE	FT	
74	921575	BUMPER, FOOT, #6 SCREW,.437H	EA	4.000
75	616258	S3M-PPANH006-32X.625	EA	4.000



Assembly 407645  
 Description POWER SUPPLY ASSY, 500W -N  
 EA

Low Level Code 04  
 Revision Date 1998-10-28  
 Revision B

#	Component	Description	UM	Qty Reqd
1	405141	PCB ASSY,MONITOR	EA	1.000
2	456680	PANEL,FRONT,PWR SUPPLY	EA	1.000
3	456681	ENCLOSURE,PWR SUPPLY MTG	EA	1.000
4	500271-545	WRTEF-STR14G-5-4-5-GRN/YEL	FT	
5	521000	WRTEF-STR16G-0-0-0 BLK	FT	
6	521111	WRTEF-STR16G-1-1-1 BRN	FT	
7	521666	WRTEF-STR16G-6-6-6 BLU	FT	
8	521999	WRTEF-STR16G-9-9-9 WHT	FT	
9	522000	WRTEF-STR18G-0-0-0 BLK	FT	
10	522999	WRTEF-STR18G-9-9-9-WHT	FT	
11	601159	TRMCRP-SPD006S16-14G	EA	3.000
12	601440	TRMCRP-SPD006S22-18G	EA	2.000
13	601509	TRMCRP-RNG006S16-14G	EA	1.000
14	602237-206	CON-PCB-RCP006C.100D	EA	1.000
15	602337	SWITCH,ROCKER,DPST,16A	EA	1.000
16	602339-004	CON-PWR-PLG004C.198D	EA	1.000
17	602340-001	TRMCRP-SNP-U-M20-14G	EA	4.000
18	611173	RVT-PP-PAN.250DX.337	EA	4.000
19	601880	TRMCRP-SNP-F-F16-14G	EA	4.000
20	615556	S1M-PFL1H006-32X.250	EA	5.000
21	615545	S1M-PFL1H004-40X.500	EA	2.000
22	616251	S3M-PPANH004-40X.250	EA	4.000
23	617167-005	NT5KPS004-40STL-ZINC	EA	2.000
25	617103	W1F006.312D.028T.147	EA	2.000
26	921551	POWER SUPPLY,500W	EA	1.000
27	611118	CLP-CA-STD.250D ADBK	EA	1.000
28	920962	LOCTITE-242-MED STR	EA	
29	611311	TRMCRP-SNP-U-F26-22G	EA	6.000
30	617167-006	NT5KPS006-32STL-ZINC 6-32SP	EA	1.000

Assembly 405130  
 Description PCB ASSY, 6-SLOT BACKPLANE -N  
 EA

Low Level Code 05  
 Revision Date 1999-08-26  
 Revision E

#	Component	Description	UM	Qty Reqd
1	P304000005	DIODE 1N4002	EA	6.000
2	000102	RSCC2-001.00K.25W005	EA	2.000
3	000331	RSCC1-330.00H.25W005	EA	2.000
4	000471	RSCC1-470.00H.25W005	EA	2.000
5	000510	RSCC1-051.00H.25W005	EA	10.000
6	010308	RSMF1-049.90H.25W001	EA	2.000
7	010921	RSMF1-825.00H.12W001	EA	1.000
8	080090	RES ARRAY 330/470TRM	EA	26.000
9	080168	RSNW2-082.000K06P05R	EA	6.000
10	110126	CPTA3-0006.8U0035V20	EA	4.000
13	130195	CPCD3-0000.1U0100V20	EA	36.000
14	230786	ICDIG-10H116P---RCVR	EA	3.000
15	231586	ICDIG-74ACT32----DIP	EA	5.000
16	415130	PCB,6-SLOT BACKPLANE	EA	1.000
18	110253	CPAE3-0150.0U0035V20LOW ESR	EA	20.000
19	921230	ADHESIVE,INSTANT-454	EA	

Assembly 405141  
 Description PCB ASSY, MONITOR -N  
 EA

Low Level Code 05  
 Revision Date 2000-04-06  
 Revision D

#	Component	Description	UM	Qty Reqd
1	R-20-5771	RSCH1-010.00H.12W005	EA	2.000
2	R-21-1802	CPCH2-0100.0N0050V20	EA	29.000
4	010308	RSMF1-049.90H.25W001	EA	3.000
6	040197	PTST2-CM010.0K-PC-TA	EA	1.000
8	040332	PTST1-CM100.0H-PC-SA	EA	1.000
10	050000-104	RSCH2-100.00K.06W005	EA	1.000
12	050000-105	RSCH3-001.00M.06W005	EA	1.000
14	050000-132	RSCH2-001.30K.06W005	EA	2.000
18	050000-432	RSCH2-004.30K.06W005	EA	5.000
20	050000-471	RSCH1-470.00H.06W005	EA	19.000
22	050009	RSCH2-001.00K.06W001	EA	5.000
24	050027	RSCH -200.00K.06W001	EA	2.000
26	050030	RSCH2-010.20K.06W001	EA	2.000
28	050036	RSCH2-510.00K.12W005	EA	1.000
30	050062	RSCH2-010.00K.06W001	EA	24.000
32	050076	RSCH2-005.23K.06W001	EA	1.000
34	050085	RSCH2-015.00K.06W001	EA	1.000
36	050089	RSCH2-049.90K.06W001	EA	2.000
38	050090	RSCH2-110.00K.06W001	EA	2.000
40	050094	RSCH2-003.65K.06W001	EA	1.000
42	050096-002	RSCH2-010.00K.10W.10	EA	2.000
44	050117-009	RSCH2-024.90K.10W001	EA	1.000
46	110244	CPCH3-0001.0U0016V10	EA	1.000
48	130186	CPCH3-0010.0U0016V10	EA	1.000
50	200320	TRBI-NPNSG-SS60V350M	EA	5.000
52	210128	DISLC-070.0V00.20A	EA	2.000
54	210151	DILED-001.7V00.02A-LHG3392	EA	9.000
56	231093	ICLIN-LM339-----COMP	EA	8.000
58	231520	ICLIN-LM324AD---SOIC	EA	2.000
60	231587	ICLIN-336-2.5V-SOIC	EA	1.000
62	231591	ICLIN-LM50-----SOIC	EA	1.000
64	310271	RSTM1-100.00H001W.01	EA	2.000
66	415141	PCB,MONITOR	EA	1.000
69	500329	CAFT-RBN-14C28G-1STR	EA	1.000
71	601208-011	CON-PCB-PLG04SD.100S	EA	1.000
73	601208-015	CON-PCB-PLG10PC.100S	EA	1.000
75	602338-014	CON-FCA-PLG014I.100D	EA	1.000
77	602238-006	CON-PCB-PLG006P.100D	EA	1.000
79	602091-014	CON-FCA-PLG2014.100D	EA	1.000
81	500330-001	TBGSTD-POL.235ID-CLR.38ODMOD	EA	1.000
82	921055	TAPE-DBL SIDED-FOAM	EA	

Racal Instruments, Inc.

Assembly 407669

Conn Assy, 50 Pin, Low Profile

Date 10/02/98

Revision A

#	Component	Description	U/N	Qty Reqd
1	456701	BACKSHELL,50 PIN,LOW PROFILE	-D BA	1.000
2	456702	STRAIN RELIEF,LOW PROFILE	-D BA	1.000
3	601855-050-001	CONN~50 PIN PLUG,MODIFIED	-D BA	1.000
4	610935	W2H006.141x.320x.050	-E BA	2.000
5	616252	S3M-PPANHOO4-40X.312	-E BA	2.000

## Chapter 6

# PRODUCT SUPPORT

---

### Product Support

Racal Instruments has a complete Service and Parts Department. If you need technical assistance or should it be necessary to return your product for repair or calibration, call 1-800-722-3262. If parts are required to repair the product at your facility, call 1-949-859-8999 and ask for the Parts Department.

When sending your instrument in for repair, complete the form in the back of this manual.

For worldwide support and the office closes to your facility, refer to the Support Offices section on the following page.

### Warranty

Use the original packing material when returning the 1264C to Racal Instruments for calibration or servicing. The original shipping crate and associated packaging material will provide the necessary protection for safe reshipment.

If the original packing material is unavailable, contact Racal Instruments Customer Service for information.

## Support Offices

### RACAL INSTRUMENTS

#### United States

(Corporate Headquarters and Service Center)  
4 Goodyear Street, Irvine, CA 92618  
Tel: (800) 722-2528, (949) 859-8999; Fax: (949) 859-7139

5730 Northwest Parkway Suite 700, San Antonio, TX 78249  
Tel: (210) 699-6799; Fax: (210) 699-8857

#### Europe

(European Headquarters and Service Center)  
18 Avenue Dutartre, 78150 LeChesnay, France  
Tel: +33 (0)1 39 23 22 22; Fax: +33 (0)1 39 23 22 25

29-31 Cobham Road, Wimborne, Dorset BH21 7PF, United Kingdom  
Tel: +44 (0) 1202 872800; Fax: +44 (0) 1202 870810

Via Milazzo 25, 20092 Cinisello B, Milan, Italy  
Tel: +39 (0)2 6123 901; Fax: +39 (0)2 6129 3606

Racal Instruments Group Limited, Technologie Park  
D-51429 Bergisch Gladbach  
Tel: +49 2204 844205; Fax: +49 2204 844219

### REPAIR AND CALIBRATION REQUEST FORM

To allow us to better understand your repair requests, we suggest you use the following outline when calling and include a copy with your instrument to be sent to the Racal Instruments Repair Facility.

Model \_\_\_\_\_ Serial No. \_\_\_\_\_ Date \_\_\_\_\_

Company Name \_\_\_\_\_ Purchase Order # \_\_\_\_\_

Billing Address \_\_\_\_\_  
City \_\_\_\_\_

---

State/Province	Zip/Postal Code	Country
----------------	-----------------	---------

Shipping Address \_\_\_\_\_  
City \_\_\_\_\_

---

State/Province	Zip/Postal Code	Country
----------------	-----------------	---------

Technical Contact \_\_\_\_\_ Phone Number ( ) \_\_\_\_\_

Purchasing Contact \_\_\_\_\_ Phone Number ( ) \_\_\_\_\_

1. Describe, in detail, the problem and symptoms you are having. Please include all set up details, such as input/output levels, frequencies, waveform details, etc.

---

---

---

---

2. If problem is occurring when unit is in remote, please list the program strings used and the controller type.

---

---

---

---

3. Please give any additional information you feel would be beneficial in facilitating a faster repair time (i.e., modifications, etc.)

---

---

---

---

4. Is calibration data required?      Yes   No   (please circle one)

Call before shipping                      Ship instruments to nearest support office.

Note: We do not accept  
"collect" shipments.

This page was left intentionally blank.



# Appendix A

## SPECIFICATIONS

---

### Specifications

This chapter contains the complete specifications for the 1264C Mainframe.

**Table A-1, AC Input Specifications**

Characteristic	Description
Input Voltage Range	115 VAC $\pm$ 10% 230 VAC $\pm$ 10% (Switch settable at S400)
Input Frequency Range	47 Hz to 63 Hz
Power Consumption	1000 W line power maximum
Fuse Rating  115VAC Operation 230VAC - 250 V Operation (Option 71)	0.25 in x 1.25 in, Slow Blow, 15 A, 250 V 5 mm x 20 mm, T6.3 A, 250 V
Inrush Current	70 A maximum, cold start
Input current	12 A maximum
Power Disconnect	Front Panel AC Power Switch

Table A-2, DC Output Power

Characteristic	Description																								
Maximum Power Available To Modules	500 W, 0°C to 50°C, Derate 2.5%/°C above 50°C																								
Useable Power	790W																								
DC Current Capacity ( $I_{MP}$ )	<table border="1"> <thead> <tr> <th>Voltage</th> <th><math>I_{MP}</math> (Steady-State Current)</th> <th>Power</th> </tr> </thead> <tbody> <tr> <td>+24V</td> <td>4 A</td> <td>96W</td> </tr> <tr> <td>+12 V</td> <td>8 A</td> <td>96W</td> </tr> <tr> <td>+5 V</td> <td>45 A</td> <td>225W</td> </tr> <tr> <td>-2V</td> <td>15 A</td> <td>30W</td> </tr> <tr> <td>-5.2 V</td> <td>30 A</td> <td>150W</td> </tr> <tr> <td>-12 V</td> <td>8 A</td> <td>96W</td> </tr> <tr> <td>-24 V</td> <td>4 A</td> <td>96W</td> </tr> </tbody> </table>	Voltage	$I_{MP}$ (Steady-State Current)	Power	+24V	4 A	96W	+12 V	8 A	96W	+5 V	45 A	225W	-2V	15 A	30W	-5.2 V	30 A	150W	-12 V	8 A	96W	-24 V	4 A	96W
Voltage	$I_{MP}$ (Steady-State Current)	Power																							
+24V	4 A	96W																							
+12 V	8 A	96W																							
+5 V	45 A	225W																							
-2V	15 A	30W																							
-5.2 V	30 A	150W																							
-12 V	8 A	96W																							
-24 V	4 A	96W																							
DC Voltage Regulation	<table border="1"> <thead> <tr> <th>Voltage</th> <th>Tolerance, _V</th> </tr> </thead> <tbody> <tr> <td>+24 V</td> <td>+1.2V, -720 mV</td> </tr> <tr> <td>+12 V</td> <td>+600 mV, -360mV</td> </tr> <tr> <td>+5V</td> <td>+250 mV, -125 mV</td> </tr> <tr> <td>-2V</td> <td>-100 mV, +100 mV</td> </tr> <tr> <td>-5.2 V</td> <td>-260 mV, +156 mV</td> </tr> <tr> <td>-12 V</td> <td>-600 mV, +360 mV</td> </tr> <tr> <td>-24 V</td> <td>-1.2 V, +720 mV</td> </tr> </tbody> </table>	Voltage	Tolerance, _V	+24 V	+1.2V, -720 mV	+12 V	+600 mV, -360mV	+5V	+250 mV, -125 mV	-2V	-100 mV, +100 mV	-5.2 V	-260 mV, +156 mV	-12 V	-600 mV, +360 mV	-24 V	-1.2 V, +720 mV								
Voltage	Tolerance, _V																								
+24 V	+1.2V, -720 mV																								
+12 V	+600 mV, -360mV																								
+5V	+250 mV, -125 mV																								
-2V	-100 mV, +100 mV																								
-5.2 V	-260 mV, +156 mV																								
-12 V	-600 mV, +360 mV																								
-24 V	-1.2 V, +720 mV																								
Maximum Load Ripple/Noise	<table border="1"> <thead> <tr> <th>Voltage</th> <th>Ripple/Noise</th> </tr> </thead> <tbody> <tr> <td>+24 V</td> <td>150 mV<sub>pp</sub></td> </tr> <tr> <td>+12 V</td> <td>50 mV<sub>pp</sub></td> </tr> <tr> <td>+5 V</td> <td>50 mV<sub>pp</sub></td> </tr> <tr> <td>-2 V</td> <td>50 mV<sub>pp</sub></td> </tr> <tr> <td>-5.2 V</td> <td>50 mV<sub>pp</sub></td> </tr> <tr> <td>-12 V</td> <td>50 mV<sub>pp</sub></td> </tr> <tr> <td>-24 V</td> <td>150 mV<sub>pp</sub></td> </tr> </tbody> </table>	Voltage	Ripple/Noise	+24 V	150 mV <sub>pp</sub>	+12 V	50 mV <sub>pp</sub>	+5 V	50 mV <sub>pp</sub>	-2 V	50 mV <sub>pp</sub>	-5.2 V	50 mV <sub>pp</sub>	-12 V	50 mV <sub>pp</sub>	-24 V	150 mV <sub>pp</sub>								
Voltage	Ripple/Noise																								
+24 V	150 mV <sub>pp</sub>																								
+12 V	50 mV <sub>pp</sub>																								
+5 V	50 mV <sub>pp</sub>																								
-2 V	50 mV <sub>pp</sub>																								
-5.2 V	50 mV <sub>pp</sub>																								
-12 V	50 mV <sub>pp</sub>																								
-24 V	150 mV <sub>pp</sub>																								
Maximum Induced Ripple/Noise	<table border="1"> <thead> <tr> <th>Voltage</th> <th>Ripple/Noise</th> </tr> </thead> <tbody> <tr> <td>+24 V</td> <td>150 mV<sub>pp</sub></td> </tr> <tr> <td>+12 V</td> <td>50 mV<sub>pp</sub></td> </tr> <tr> <td>+5 V</td> <td>50 mV<sub>pp</sub></td> </tr> <tr> <td>-2 V</td> <td>50 mV<sub>pp</sub></td> </tr> <tr> <td>-5.2 V</td> <td>50 mV<sub>pp</sub></td> </tr> <tr> <td>-12 V</td> <td>50 mV<sub>pp</sub></td> </tr> <tr> <td>-24 V</td> <td>150 mV<sub>pp</sub></td> </tr> </tbody> </table>	Voltage	Ripple/Noise	+24 V	150 mV <sub>pp</sub>	+12 V	50 mV <sub>pp</sub>	+5 V	50 mV <sub>pp</sub>	-2 V	50 mV <sub>pp</sub>	-5.2 V	50 mV <sub>pp</sub>	-12 V	50 mV <sub>pp</sub>	-24 V	150 mV <sub>pp</sub>								
Voltage	Ripple/Noise																								
+24 V	150 mV <sub>pp</sub>																								
+12 V	50 mV <sub>pp</sub>																								
+5 V	50 mV <sub>pp</sub>																								
-2 V	50 mV <sub>pp</sub>																								
-5.2 V	50 mV <sub>pp</sub>																								
-12 V	50 mV <sub>pp</sub>																								
-24 V	150 mV <sub>pp</sub>																								
Dynamic Current $I_{dm}$	<table border="1"> <thead> <tr> <th>Voltage</th> <th><math>I_{dm}</math> Dynamic Current</th> </tr> </thead> <tbody> <tr> <td>+24</td> <td>3</td> </tr> <tr> <td>+12</td> <td>2</td> </tr> <tr> <td>+5</td> <td>5</td> </tr> <tr> <td>-2</td> <td>3</td> </tr> <tr> <td>-5.2</td> <td>4</td> </tr> <tr> <td>-12</td> <td>2</td> </tr> <tr> <td>-24</td> <td>3</td> </tr> </tbody> </table>	Voltage	$I_{dm}$ Dynamic Current	+24	3	+12	2	+5	5	-2	3	-5.2	4	-12	2	-24	3								
Voltage	$I_{dm}$ Dynamic Current																								
+24	3																								
+12	2																								
+5	5																								
-2	3																								
-5.2	4																								
-12	2																								
-24	3																								
Protections	Over voltage protection Over temperature protection Over current protection Short circuit protection																								

Table A-3, Cooling

Characteristic	Description
Per Slot Cooling Capacity	Typically 52W per VXI-8 rev 2.0 (for 10°C rise). <b>Figure A-1</b> shows the worst slot cooling curve of the mainframe.
Cooling System	Forced air circulation (positive pressurization).
Slot Airflow Direction	P2 to P1, bottom of module to the top of module
Mainframe Intake, Bench Top	Rear of mainframe
Module Exhaust, Bench Top	Top of mainframe.
Supply Exhaust, Bench Top	Bottom rear of mainframe.
Fan Filter Access	Filter accessible from rear of the mainframe

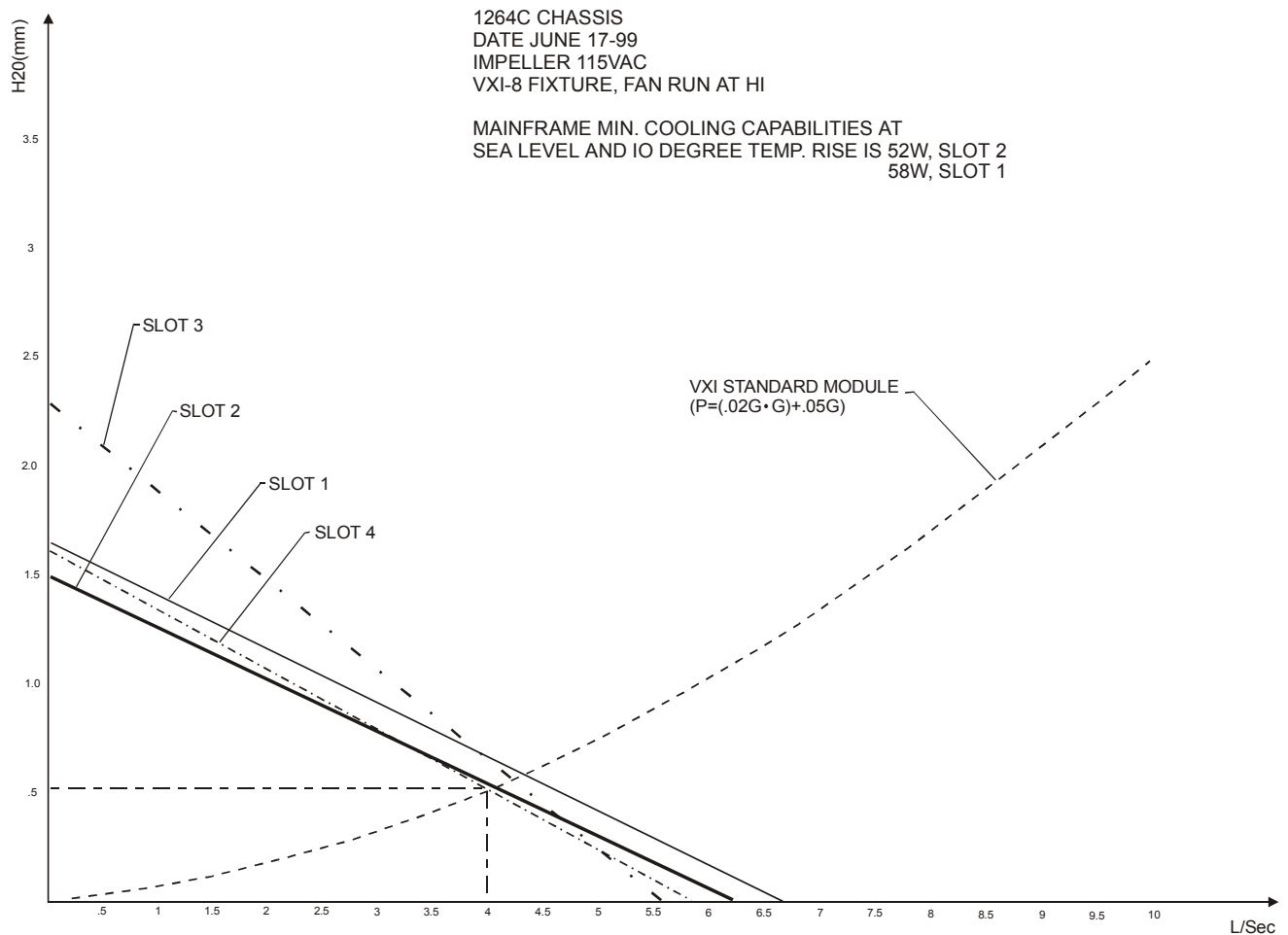

Figure A-1, Mainframe Worst Case Slot Cooling Curve

Table A-4, Safety

Characteristic	Description
Safety Characteristics	EN61010-1:1993+A2:1995
IEC Characteristics	Installation Category II Pollution Degree 2 Safety Class 1

Table A-5, Environmental

Characteristic	Description
Temperature Operating Non-operating	Meets the limits stated in MIL-T-28800E for Type III, Class 5 0°C to 50°C -40°C to 75°C
Relative Humidity Operating Non-operating	95+/-5% RH non condensing 75+/-5% RH above 30° 45+/-5% RH above 40° 95+/-5% RH at <55°
Altitude Operating Non-operating	10,000 ft. (4570m) 15,000 ft. (12,190 m)
Vibration	0.013" double amplitude, 5-55Hz
Functional Shock Operating	Half sine, 30 g, 11 ms duration.
Electromagnetic Compatibility (EMC) Emissions Immunity	Emissions shall be within the limits specified by the following requirements: EN 61326:1997+A1:1998 Class A, FCC Part 15 Class A limits for radiated emissions EN 61326:1997+A1:1998 Class A
MTBF	50,000 Hours
MTTR	< 10 minutes for major assemblies (Fan, Power Supply, backplane) < 30 minutes for monitor assembly.

**Table A-6, Backplane**

<b>Characteristic</b>	<b>Description</b>
Bus Grant/Interrupt Acknowledge	Solid state, auto-configuring (jumper less)
VXIbus CLK10 Distribution	Full differential

**Table A-7, Mechanical**

<b>Characteristic</b>	<b>Description</b>
Overall Dimensions	
Standard Mainframe (7U)	
Height	16.75 in (42.6 cm)
Width	8.7 in (22.1 cm)
Depth	21.3 in (54.1 cm)
Weight	27 lbs. (12.3 kg) with no modules installed

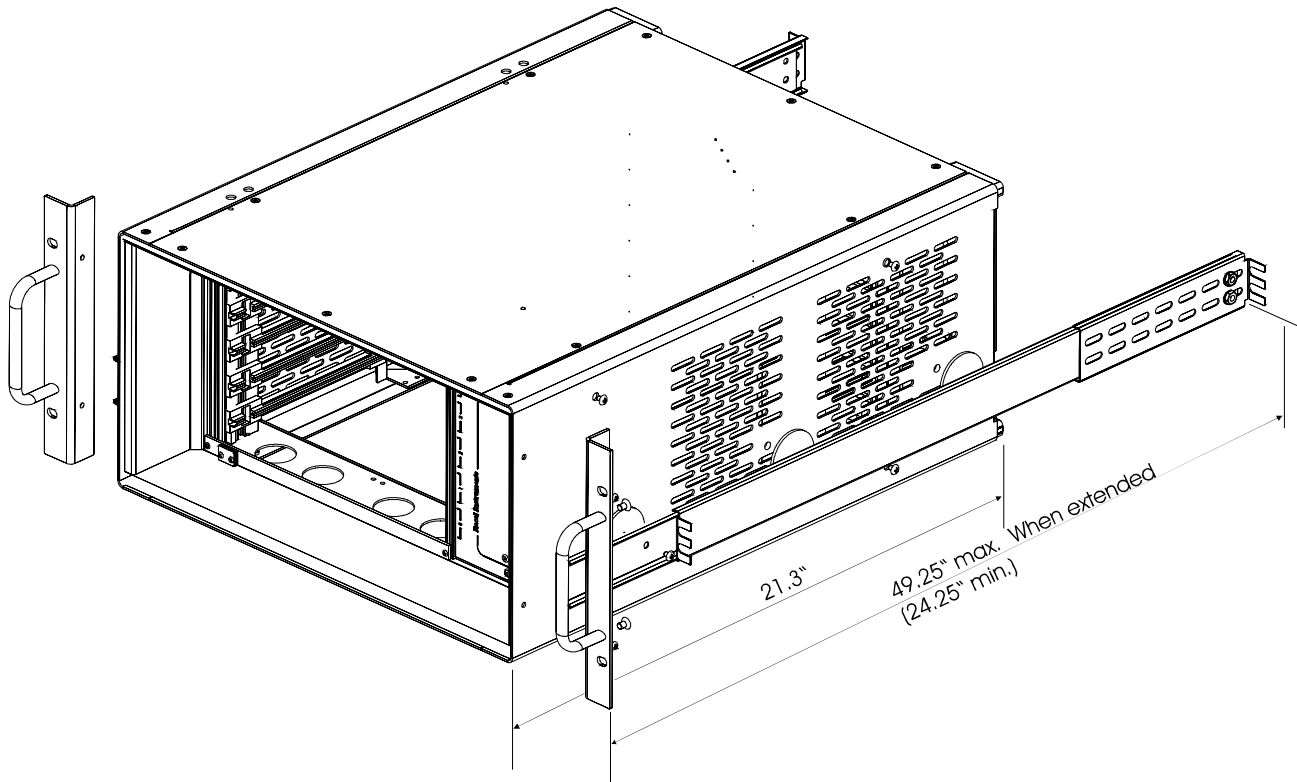

Figure A-2, View of 1264C With Rack Mount Option

Table A-8, System Monitoring Specifications, ( Typical )

Characteristics	Description
VXI Power Supply <b>Voltage</b> monitor	Default Tolerance limits: $V_{\text{nominal}} \pm 10\%$ 4% accuracy
VXI Power Supply Intake air <b>Temperature</b> monitor	Default Tolerance limits: $T_{\text{amb}} > 60^{\circ}\text{C}$ $\pm 2^{\circ}\text{C}$ accuracy
Fan monitor	Go – No Go indicator